

Modell

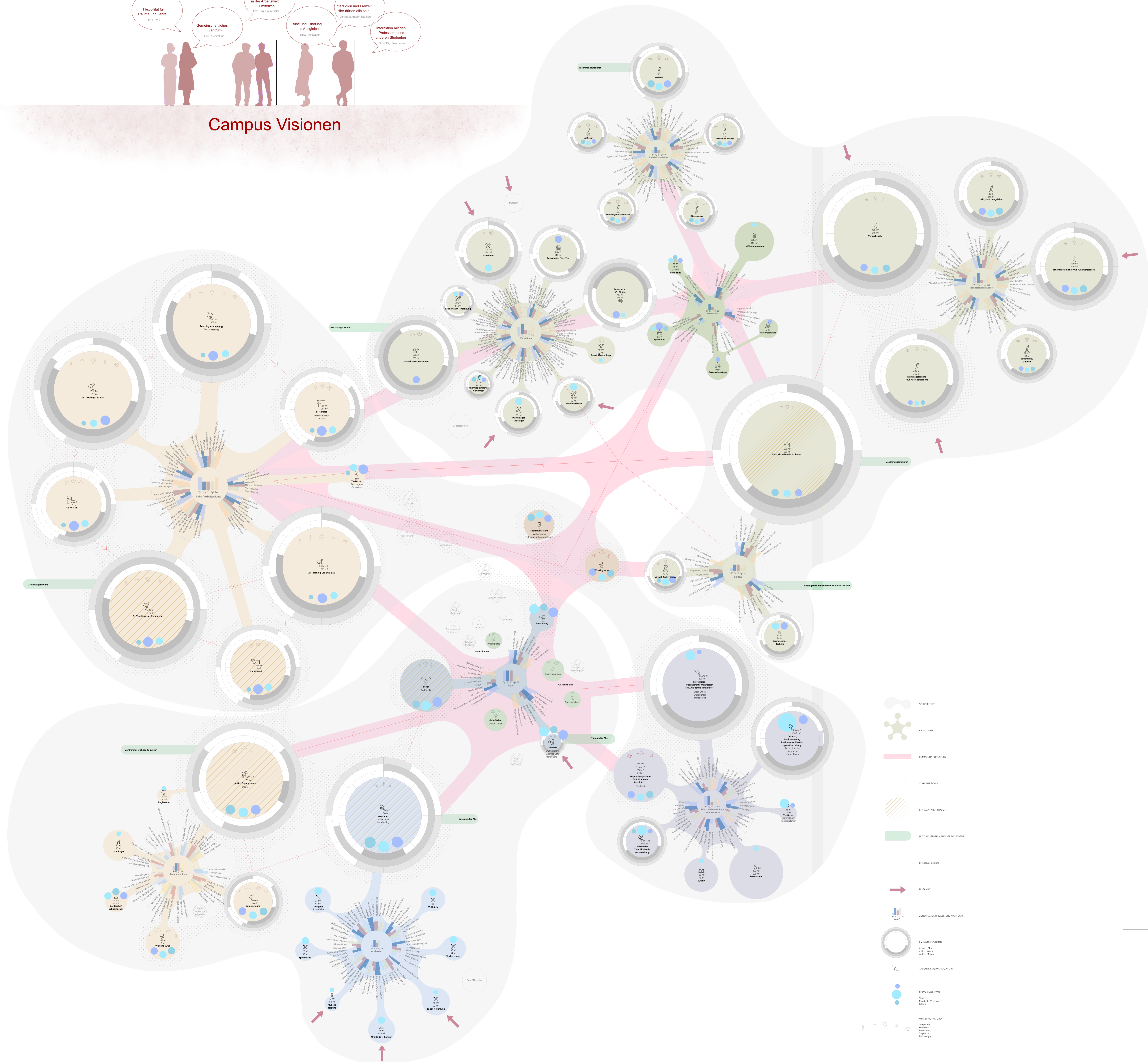

# Campus Visionen



- BILDBAUWERKE
- BAUMSTÄNDE
- WEGE/STRAßEN
- ZÄUNUNGEN
- DACHSTRUKTUREN
- NATURLANDSCHAFTEN
- WECHSELWECHSEL
- ZONEN MIT BEWEGUNGSPUNKTEN
- BILDAUSWEISER
- VERKEHRSPUNKTE
- BEWEGUNGSPUNKTE
- BEWEGUNGSPUNKTE

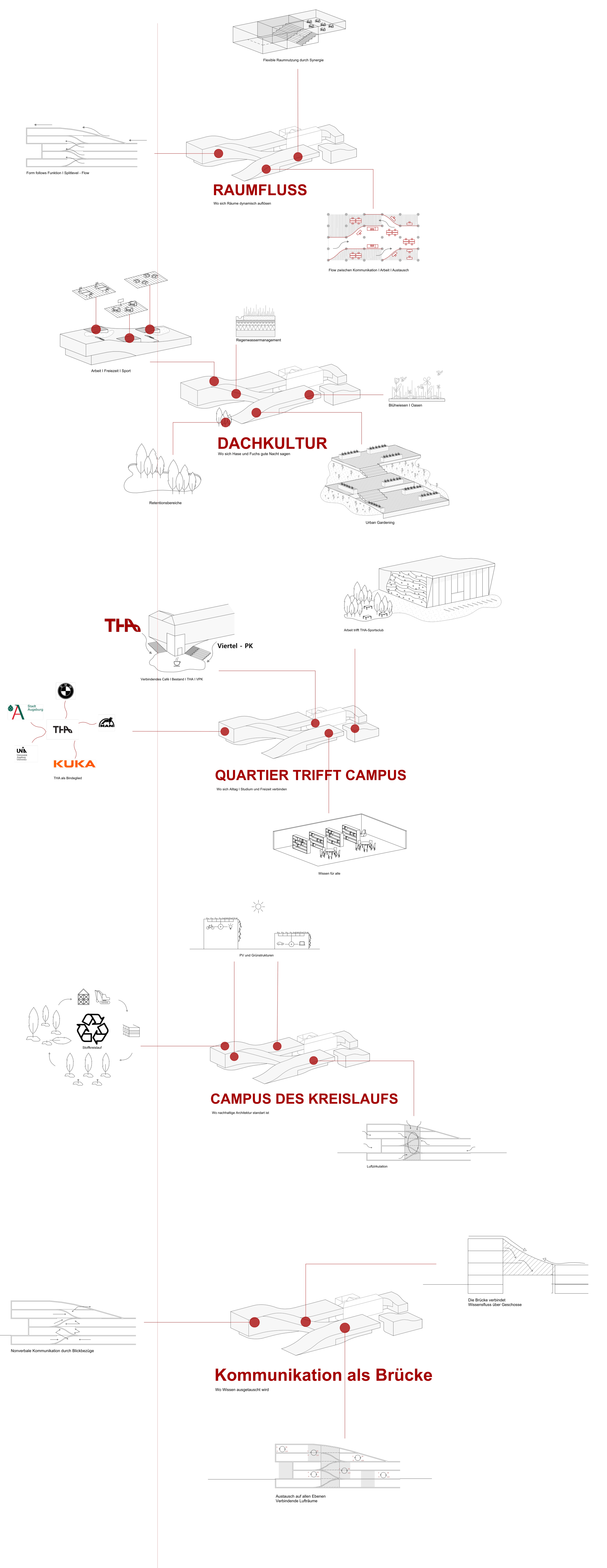

**RAUMFLUSS**  
 Wie sich Räume dynamisch aufbauen  
 Form über Funktion überfließen / Flow  
 Flow zwischen Kommunikation / Arbeit / Austausch

**DACHKULTUR**  
 Wie sich Räume und Fassade ganz neu denken  
 Dachstrukturen  
 Urban Gardening  
 Erlebens / Genuss

**THP**  
 Viertel - PK  
 THP als Wohnplatz

**QUARTIER TRIFFT CAMPUS**  
 Wie sich Quartier / Studenten und Professore verbinden  
 Wohnen für alle

**CAMPUS DES KREISLAUFS**  
 Wie nachhaltige Strukturen entstehen  
 Luftklima

**Kommunikation als Brücke**  
 Wie Räume ausgeglichen sind  
 Die Brücke verbindet Wohnen / Lernen über Generationen  
 Ausblick auf über 1000 Jahren  
 Universitätskultur

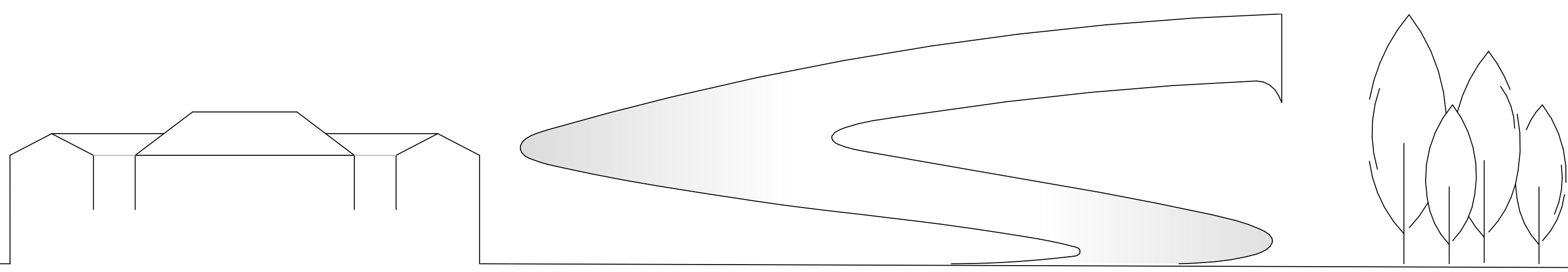

Schwarzplan

Lageplan M 1:500 ▲

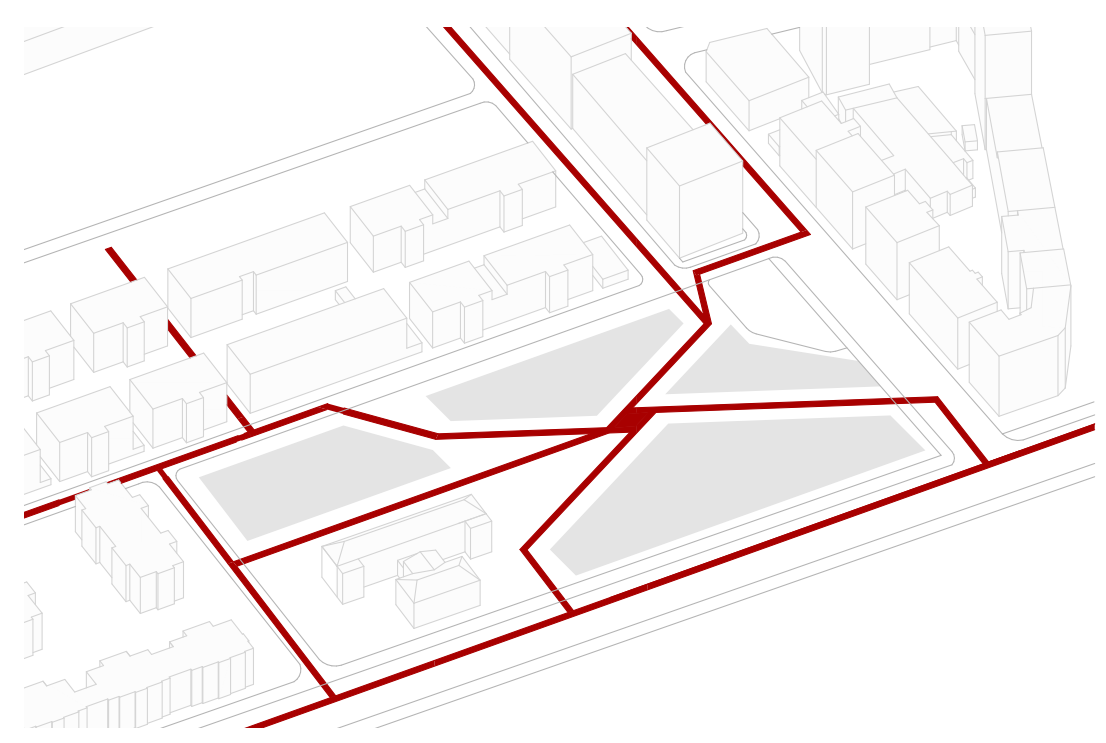

Wegeführung

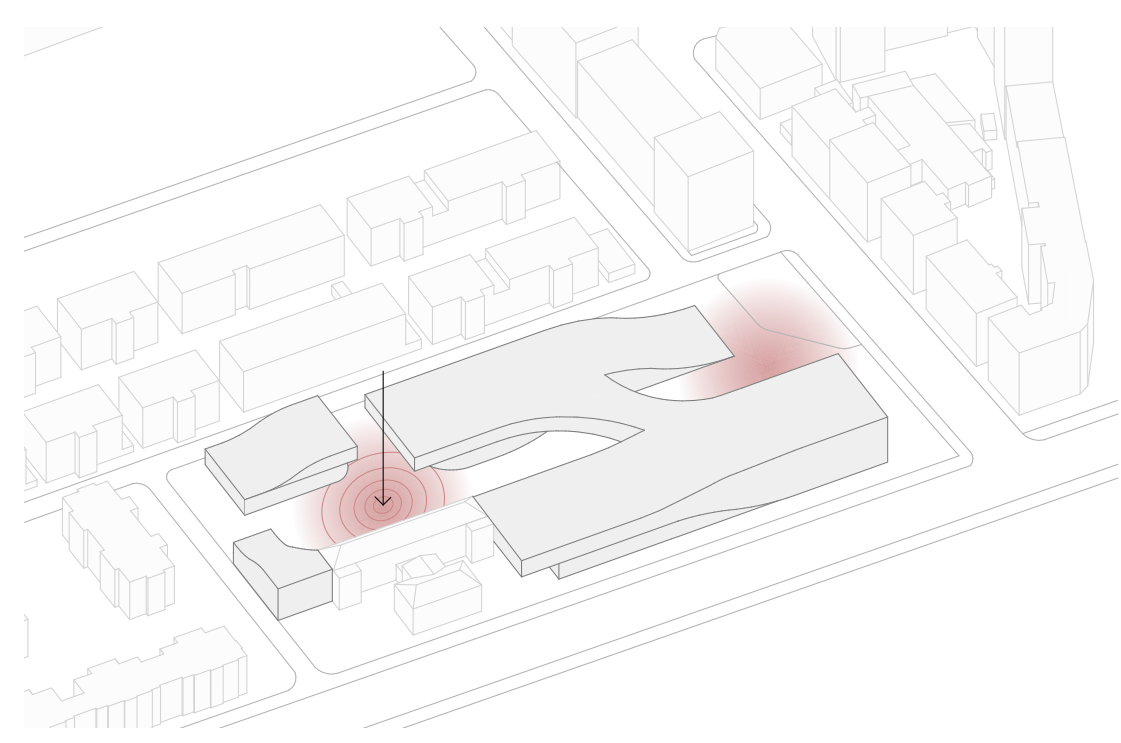

Platzbildung

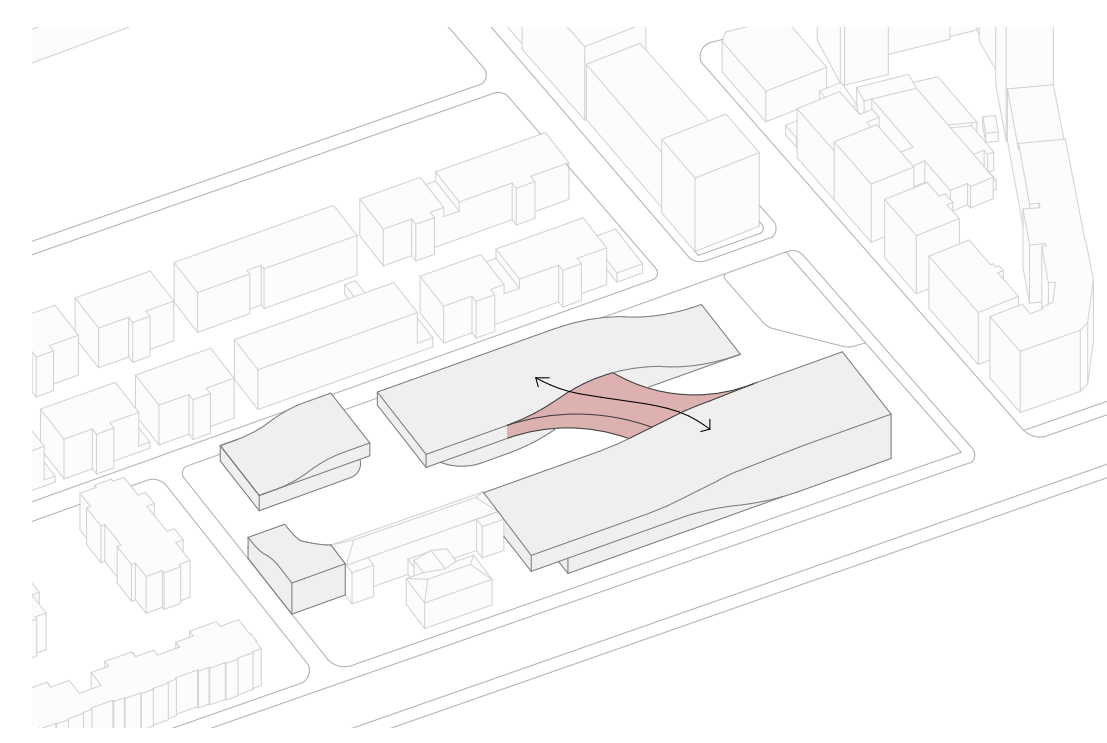

Verbindende Brücke

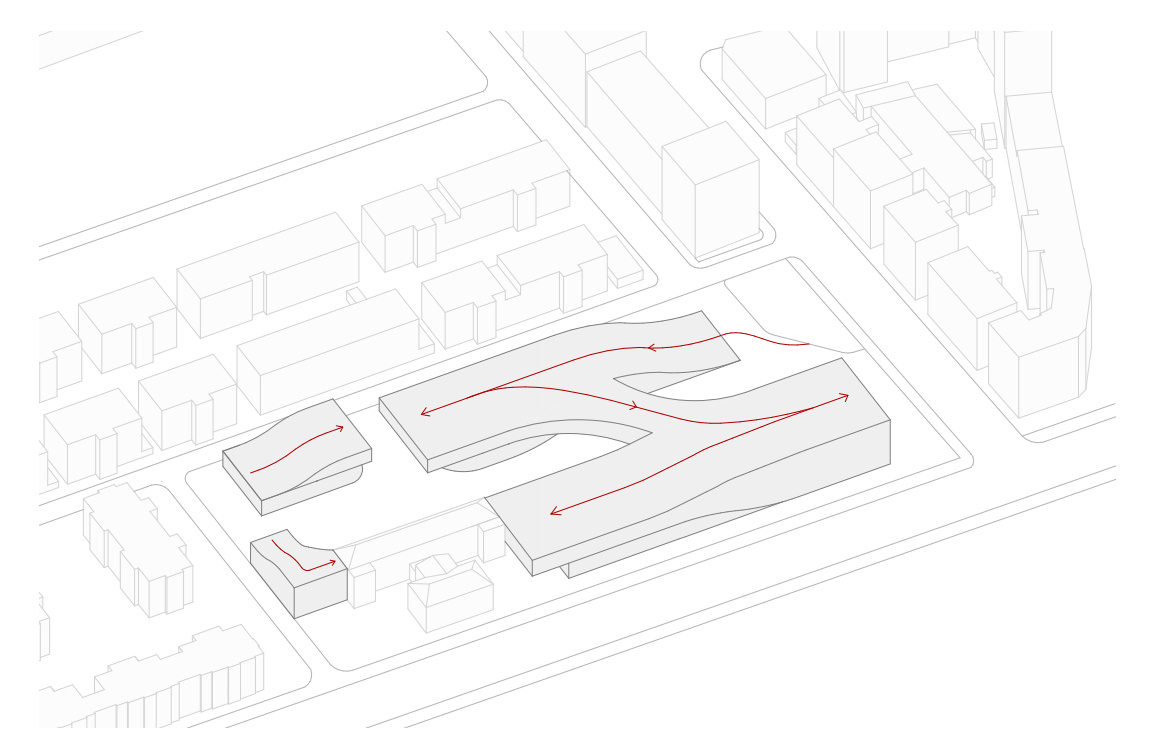

Gebäudeflow

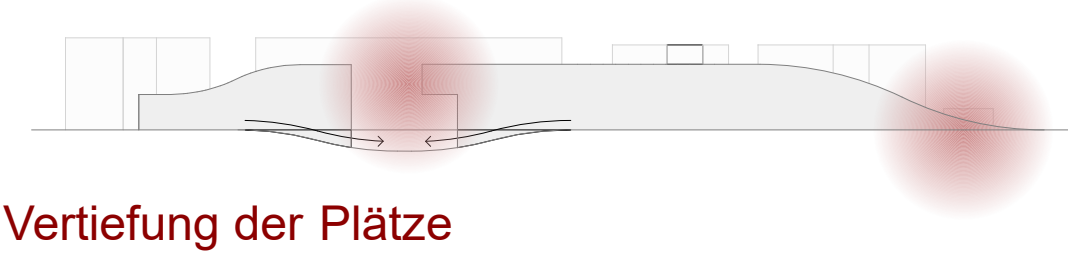

Vertiefung der Plätze

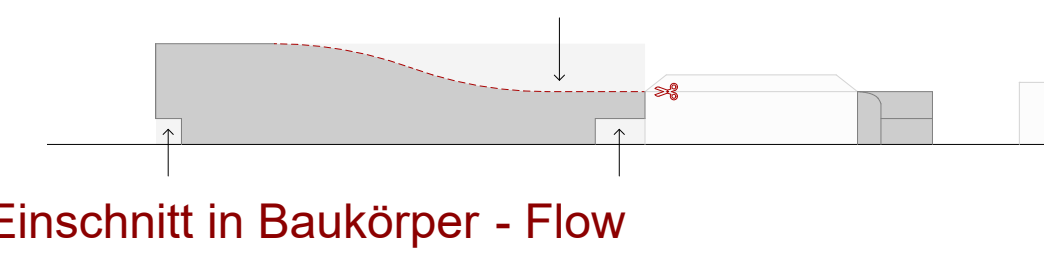

Einschnitt in Baukörper - Flow

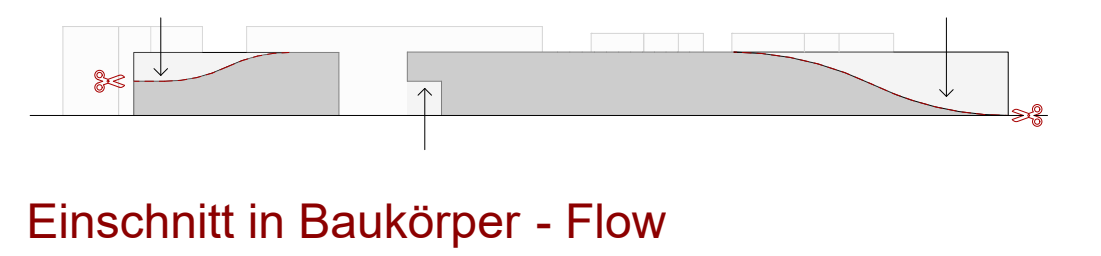

Einschnitt in Baukörper - Flow



Fangen mit Baukanten



Anlieferung | Einfahrt

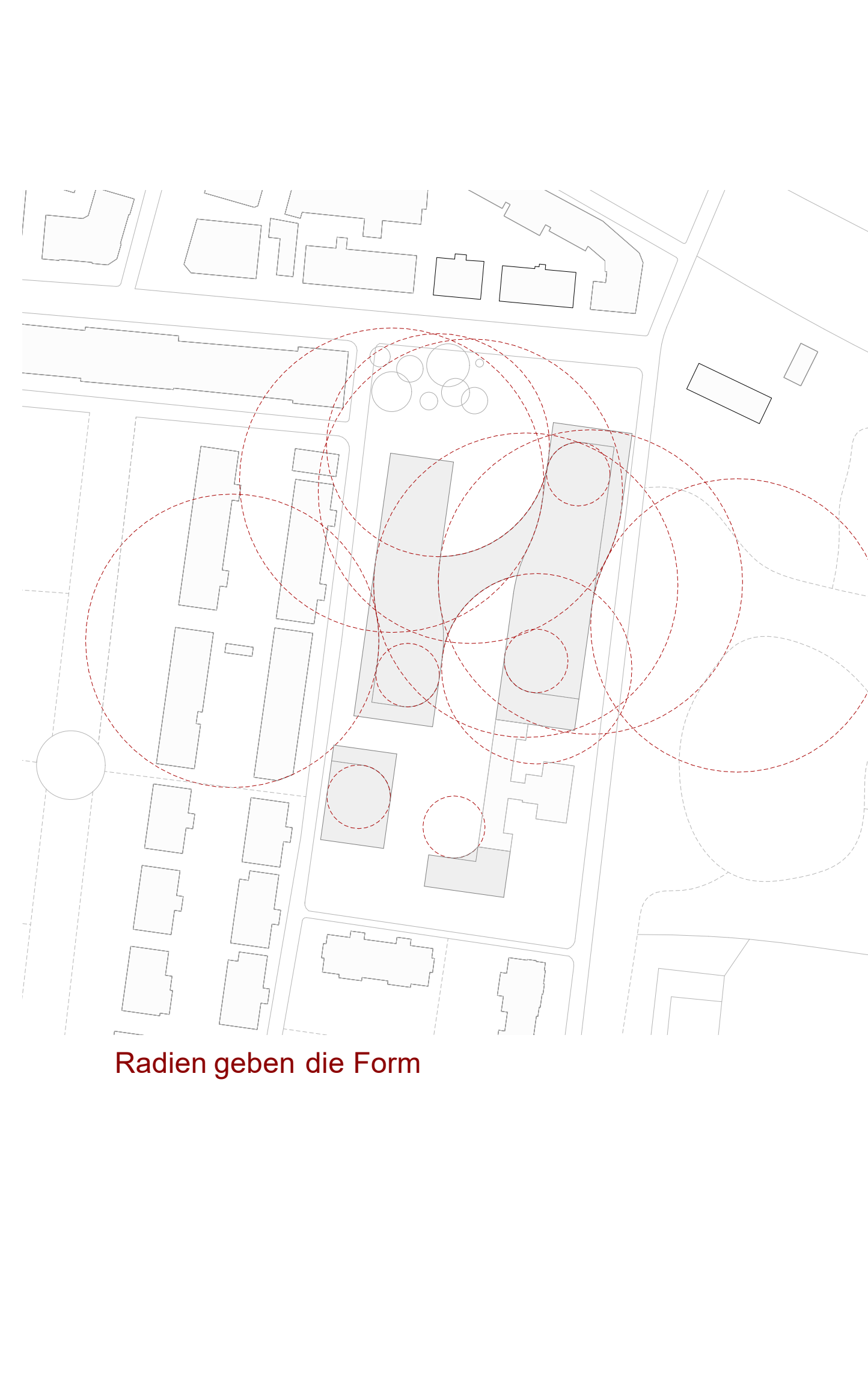

Radien geben die Form

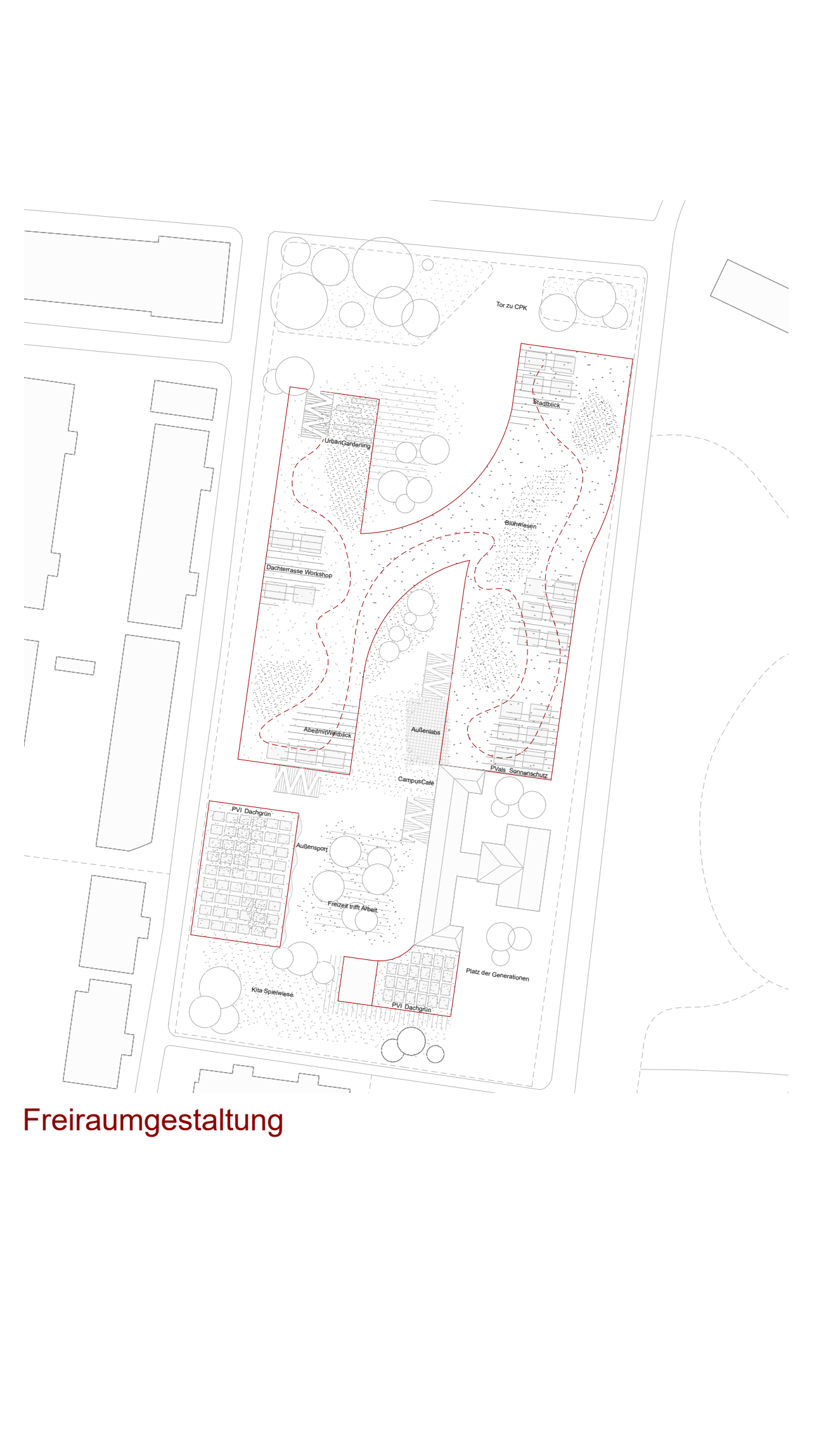

Freiraumgestaltung

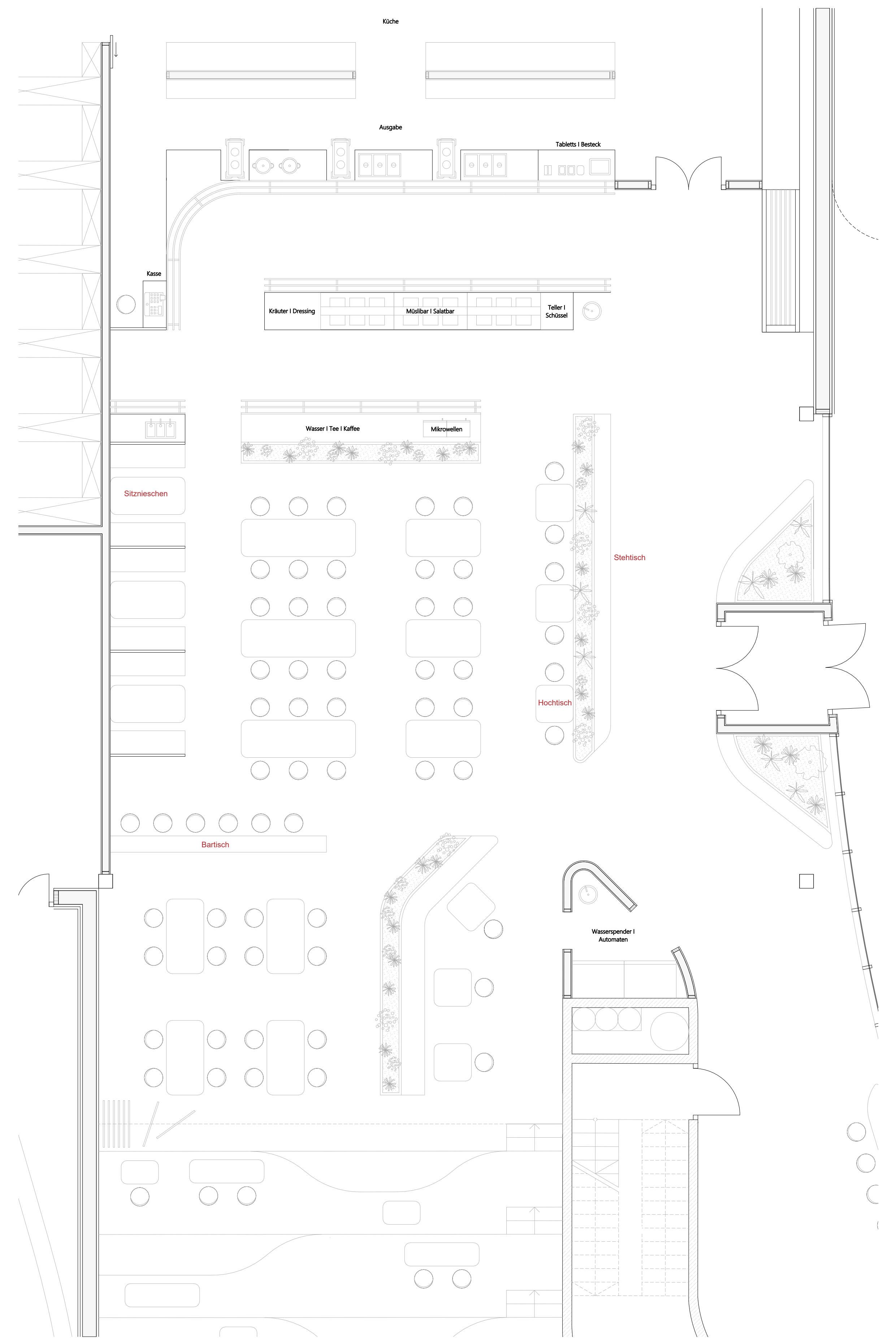
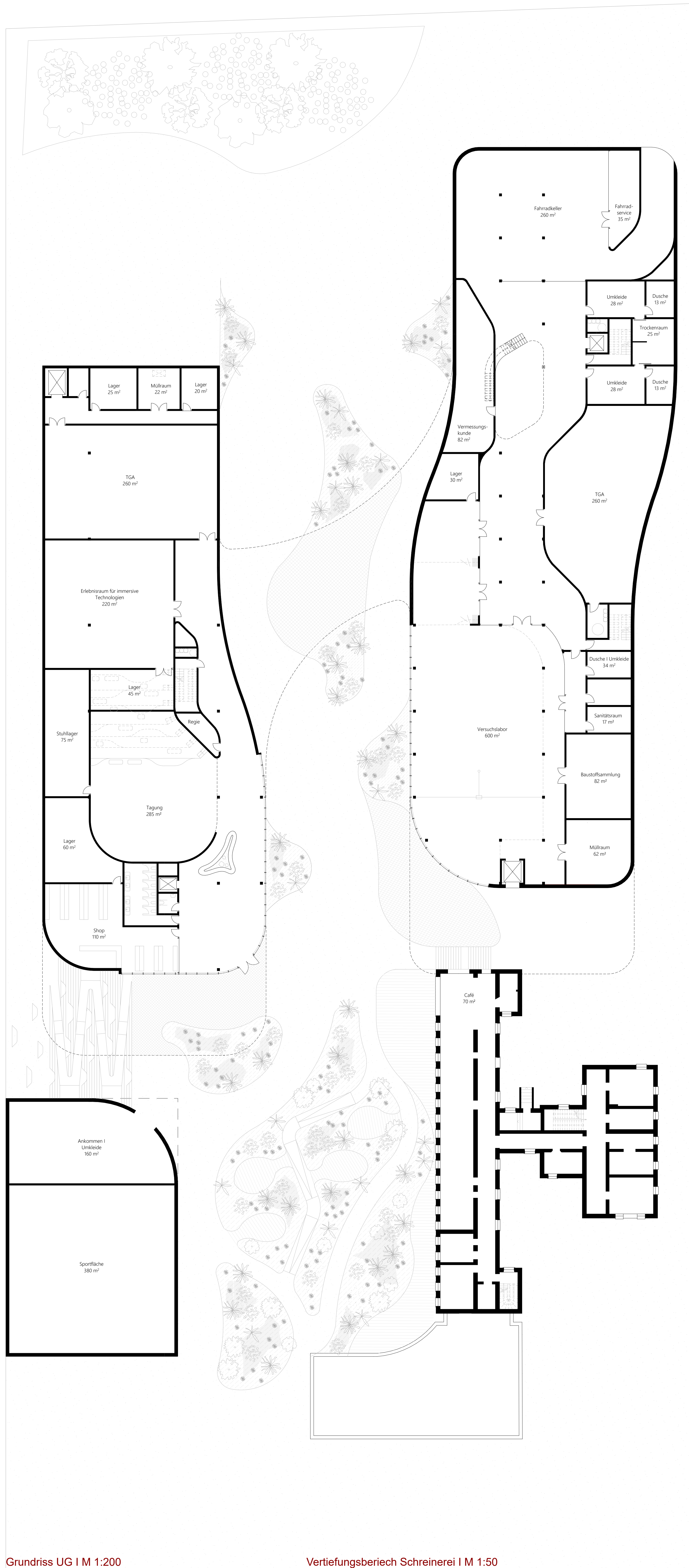

Vertiefungsbereich Mensa I M 1: 50 | Marie Schütz

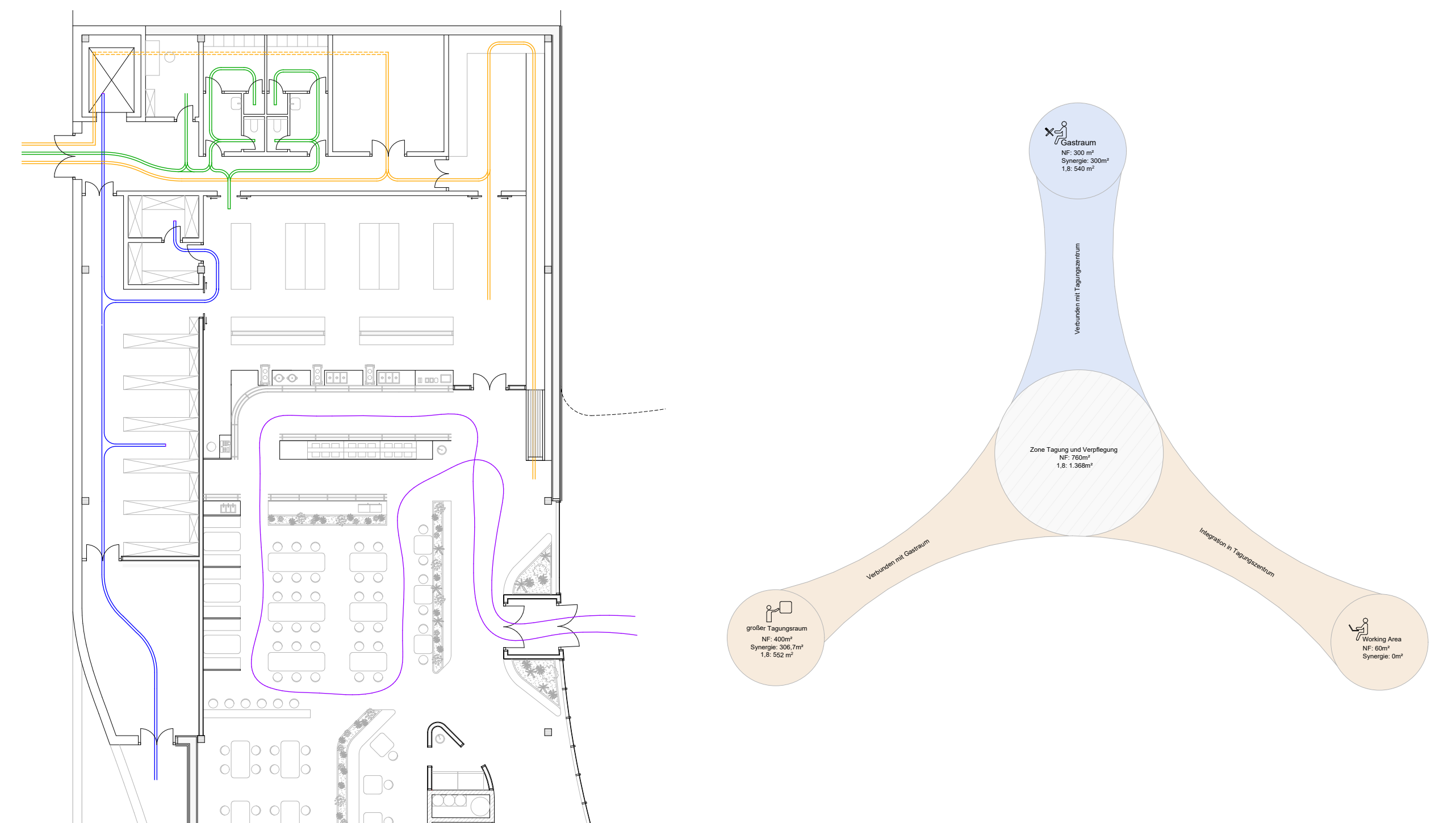

Ablaufwege Mensabetrieb

Synergiebereiche Gasträum

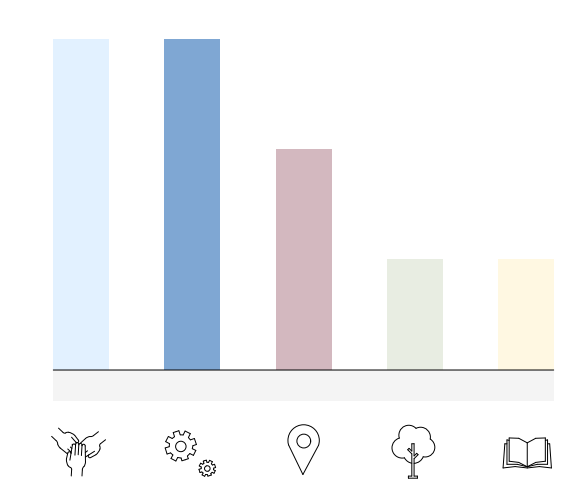

Gasträum

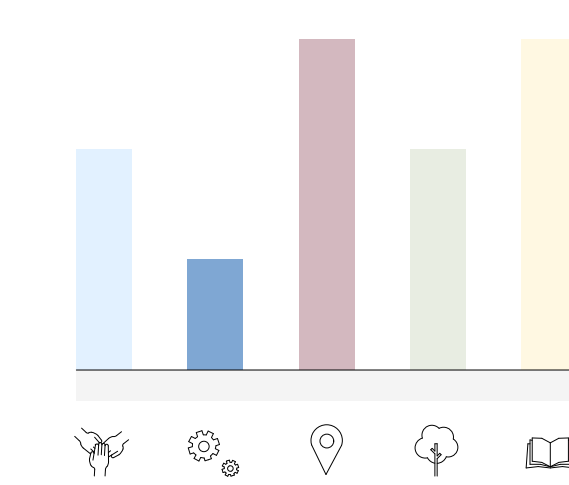

großer Tagungsraum

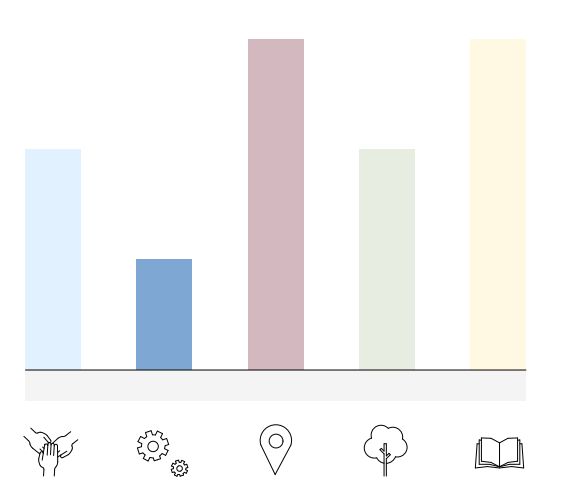

Working Area

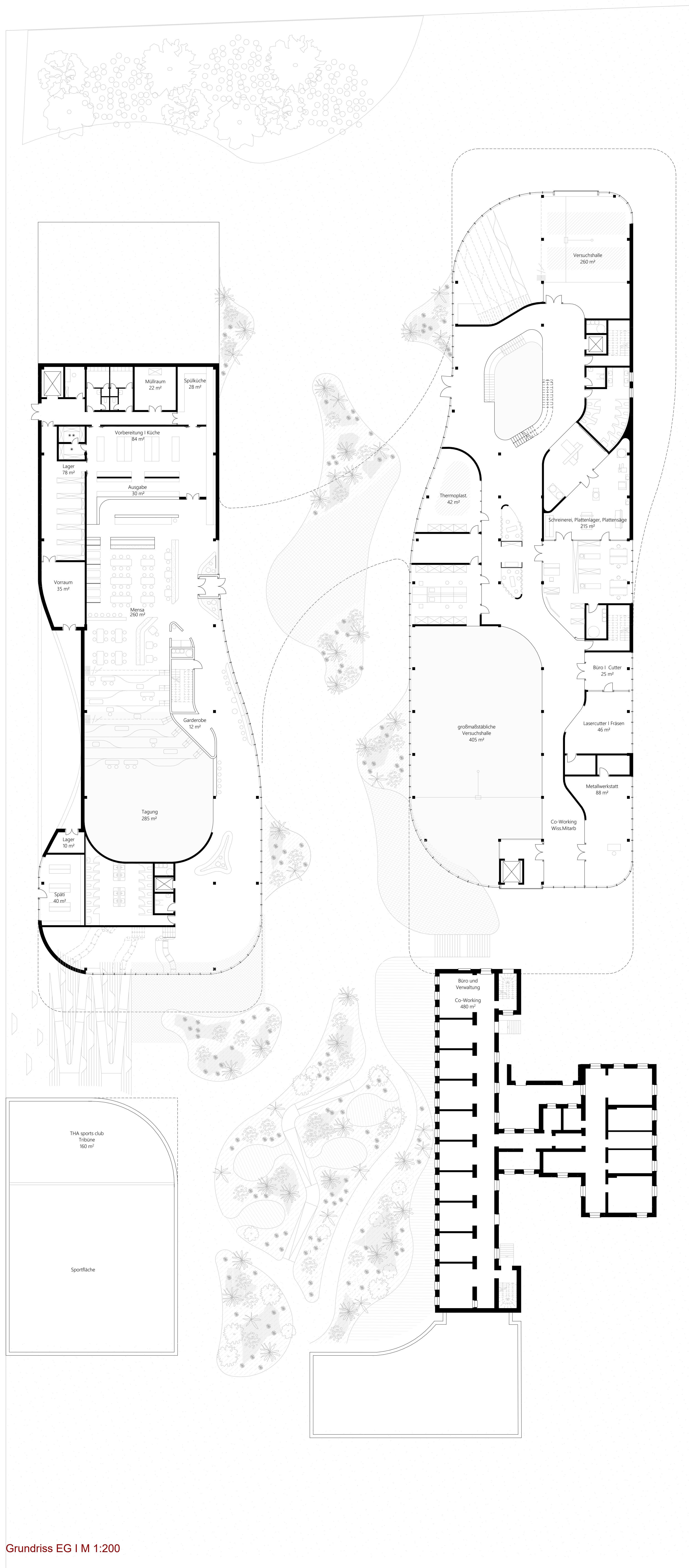

Grundriss EG | M 1:200

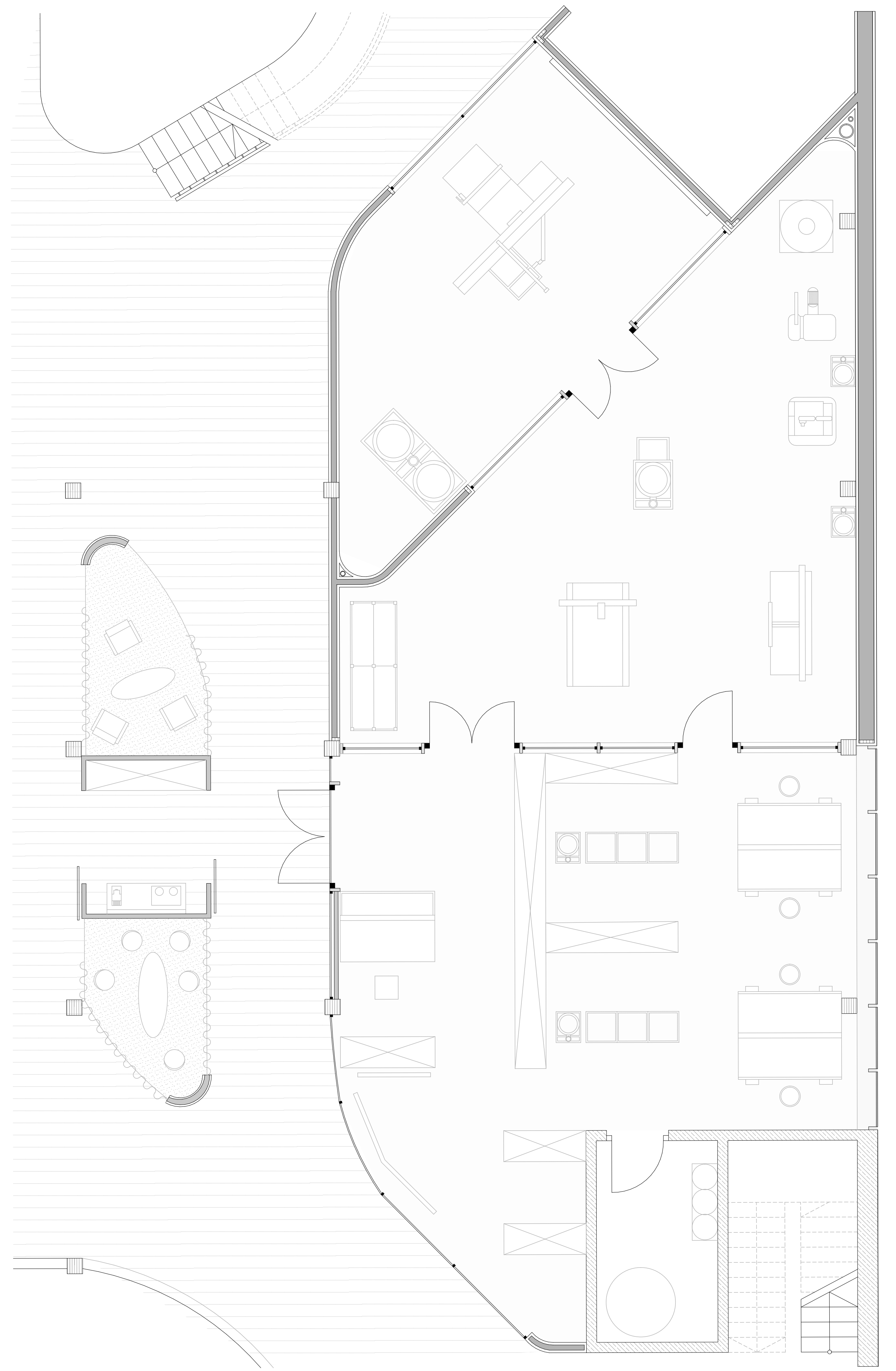

Vertiefungsbereich Schreinerei | M 1:50 | Elias Weißer

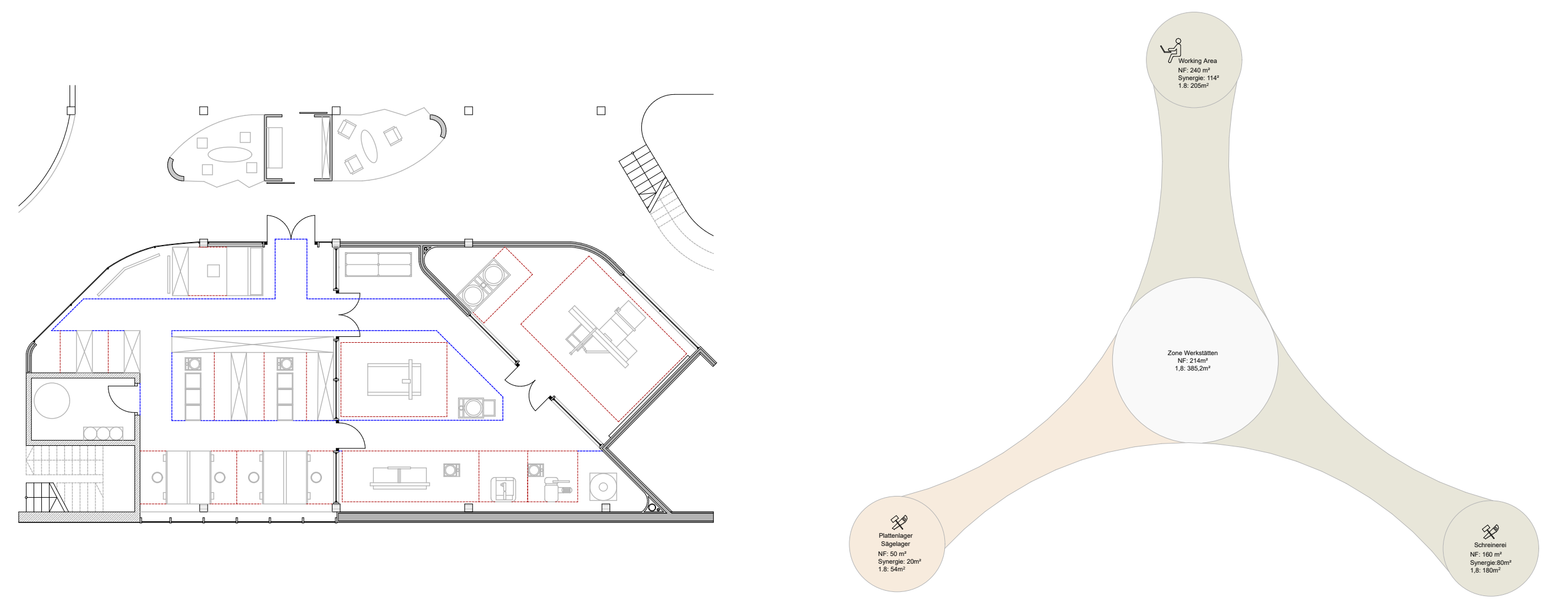

Bewegungsflächen Schreinerei

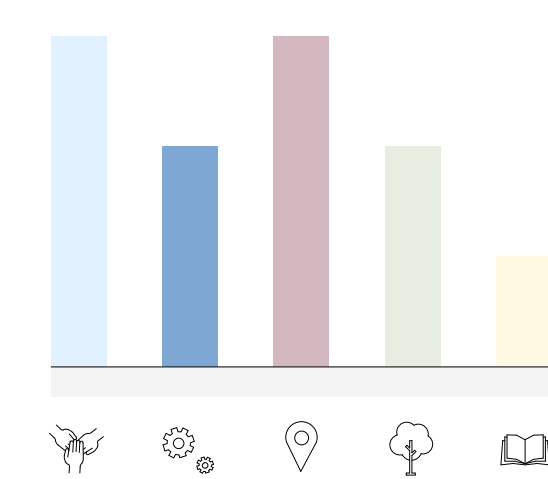

Schreinerei

Synergiebereiche Werkstatt

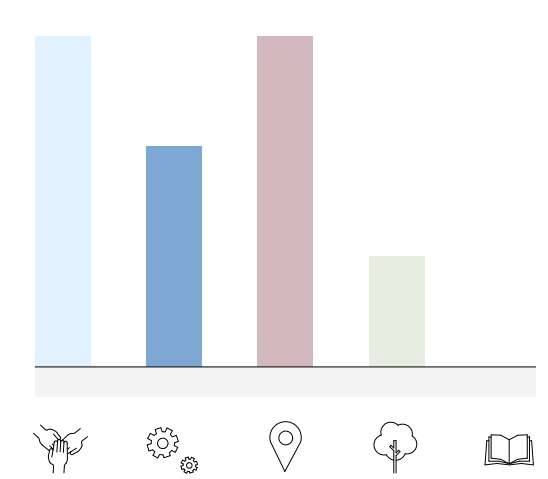

Plattenlager

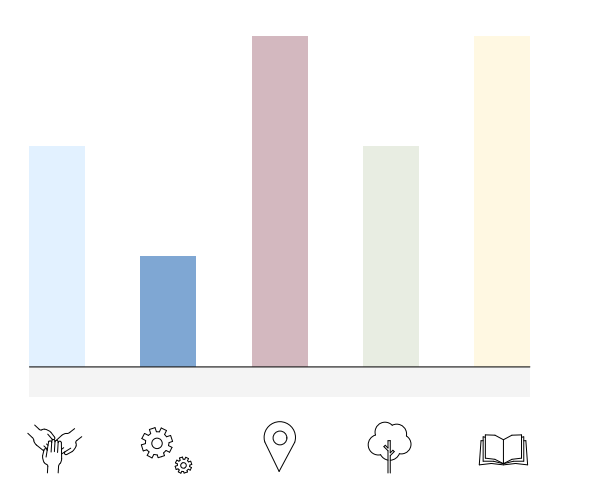

working Area

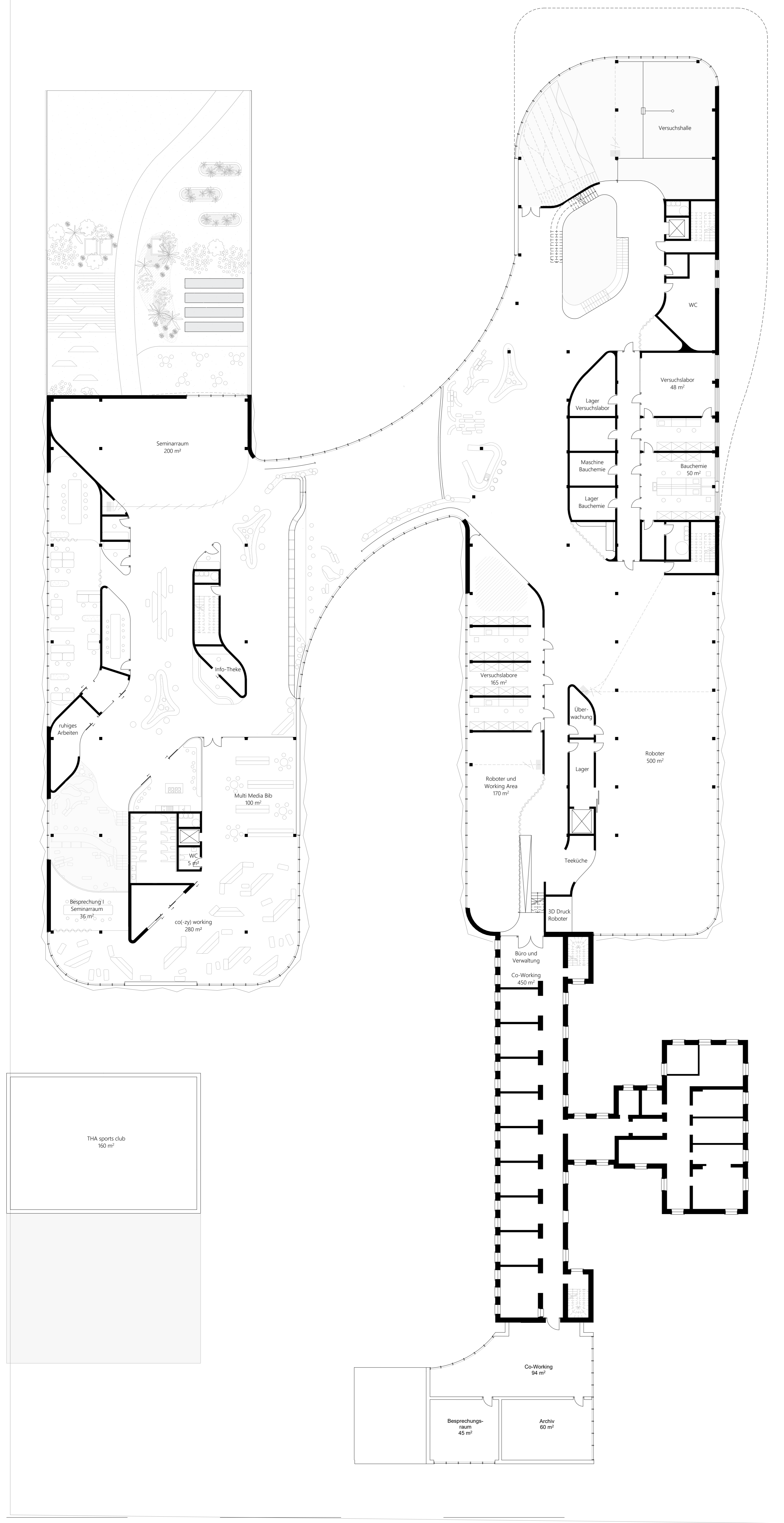

Grundriss 1 OG | M 1:200

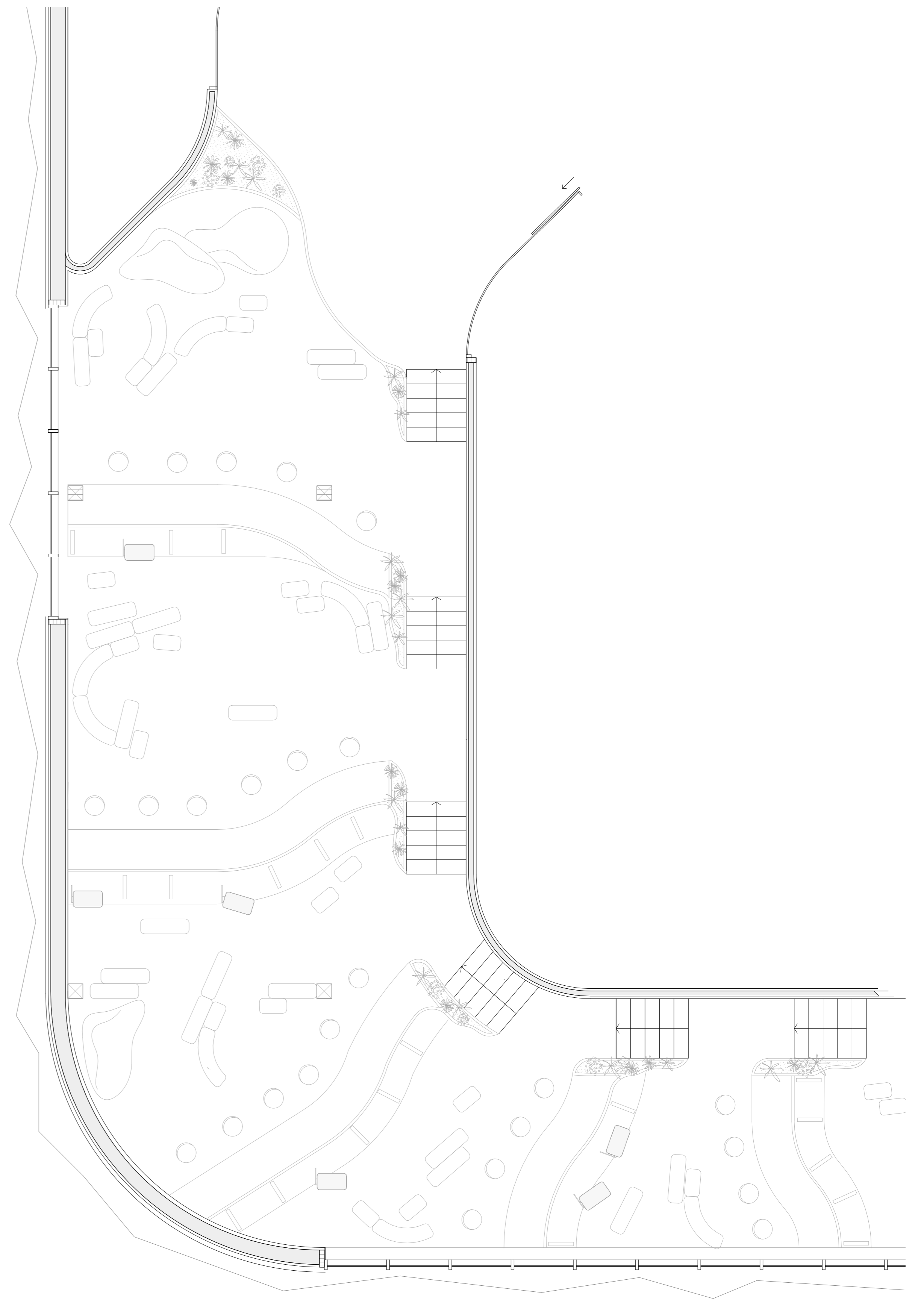

Vertiefungsbereich Co(-zy)-Working | M 1:50 | Luisa Unger

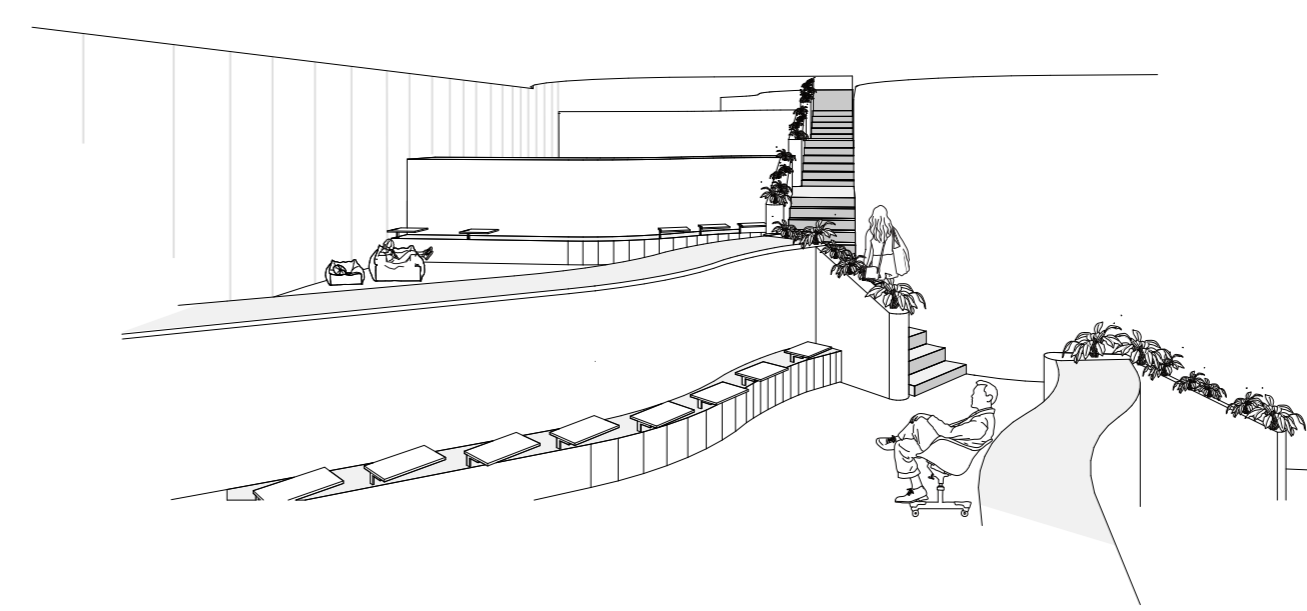

Arbeitstreppe

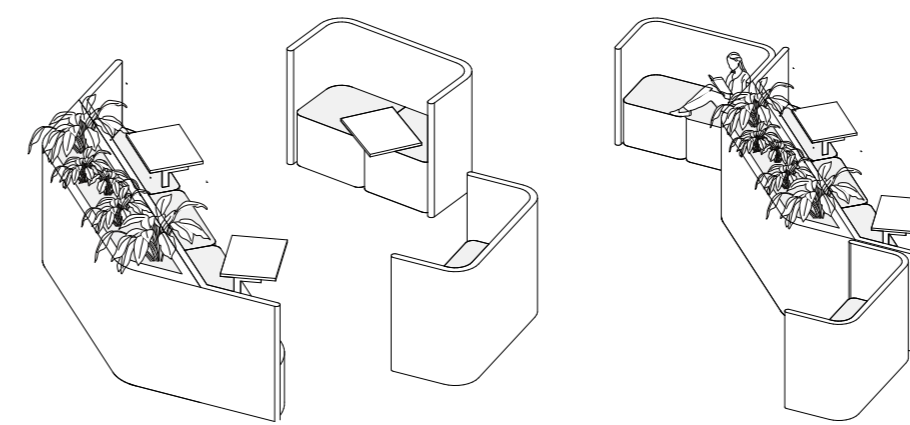

Modulare Arbeitsmöbel

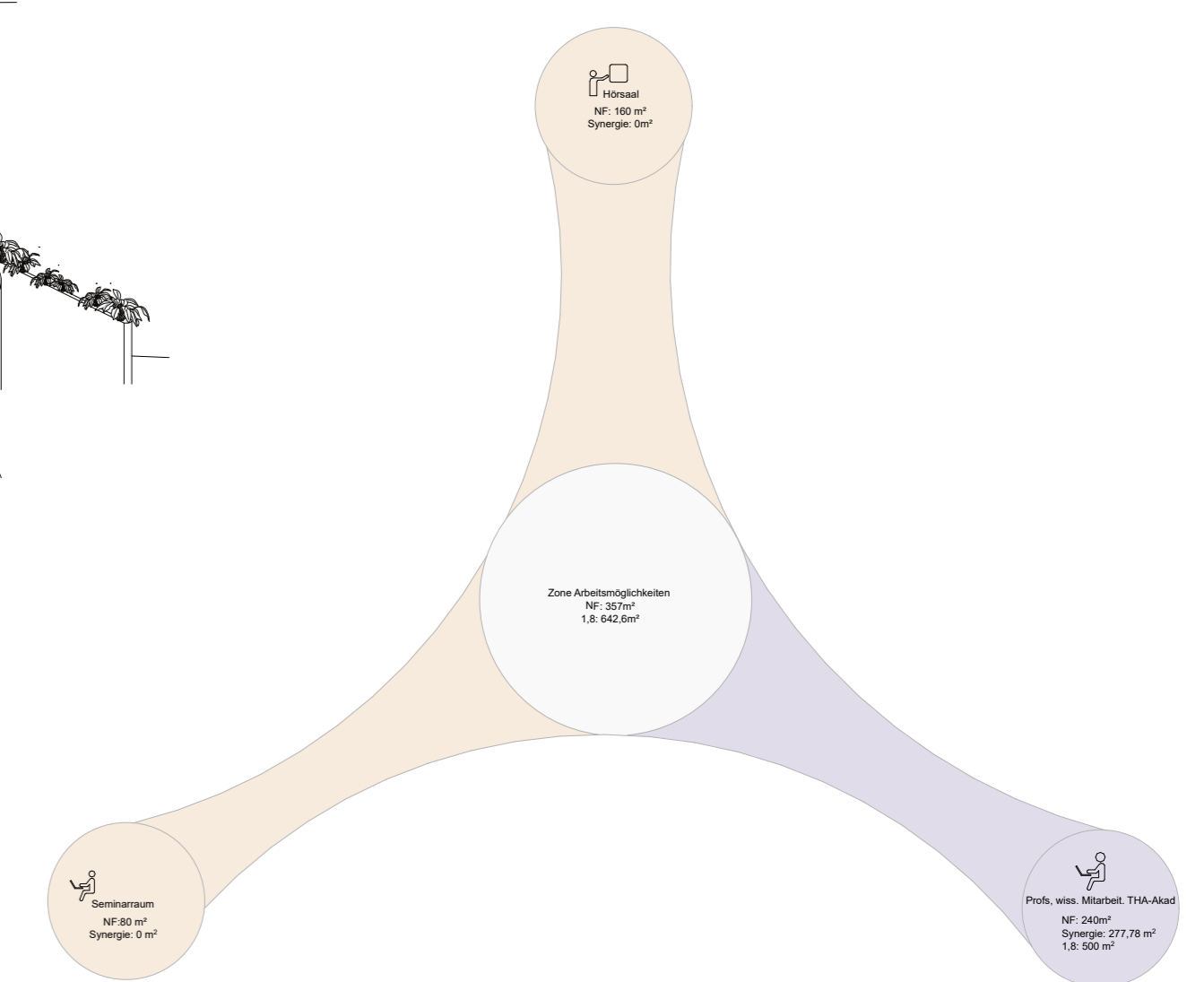

Synergiebereiche Arbeitsbereiche

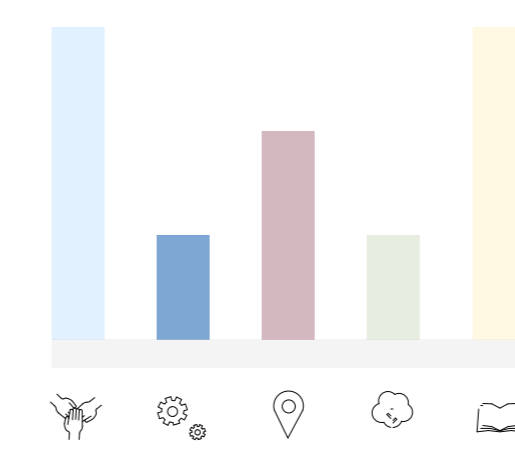

Seminarraum

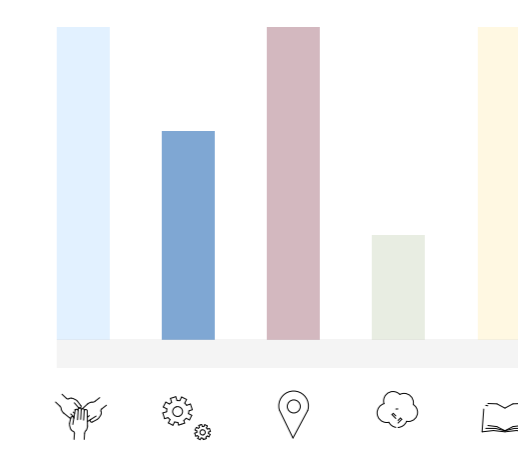

Hörsaal

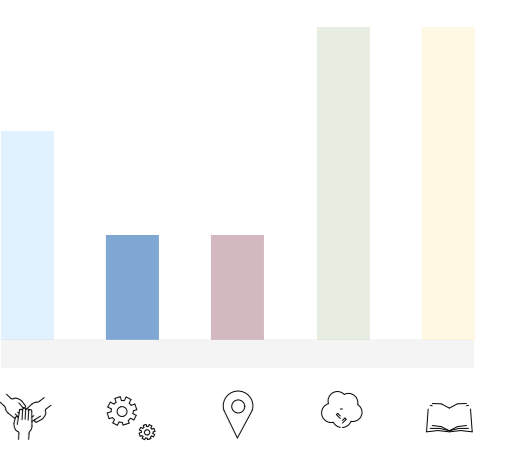

Co-Working

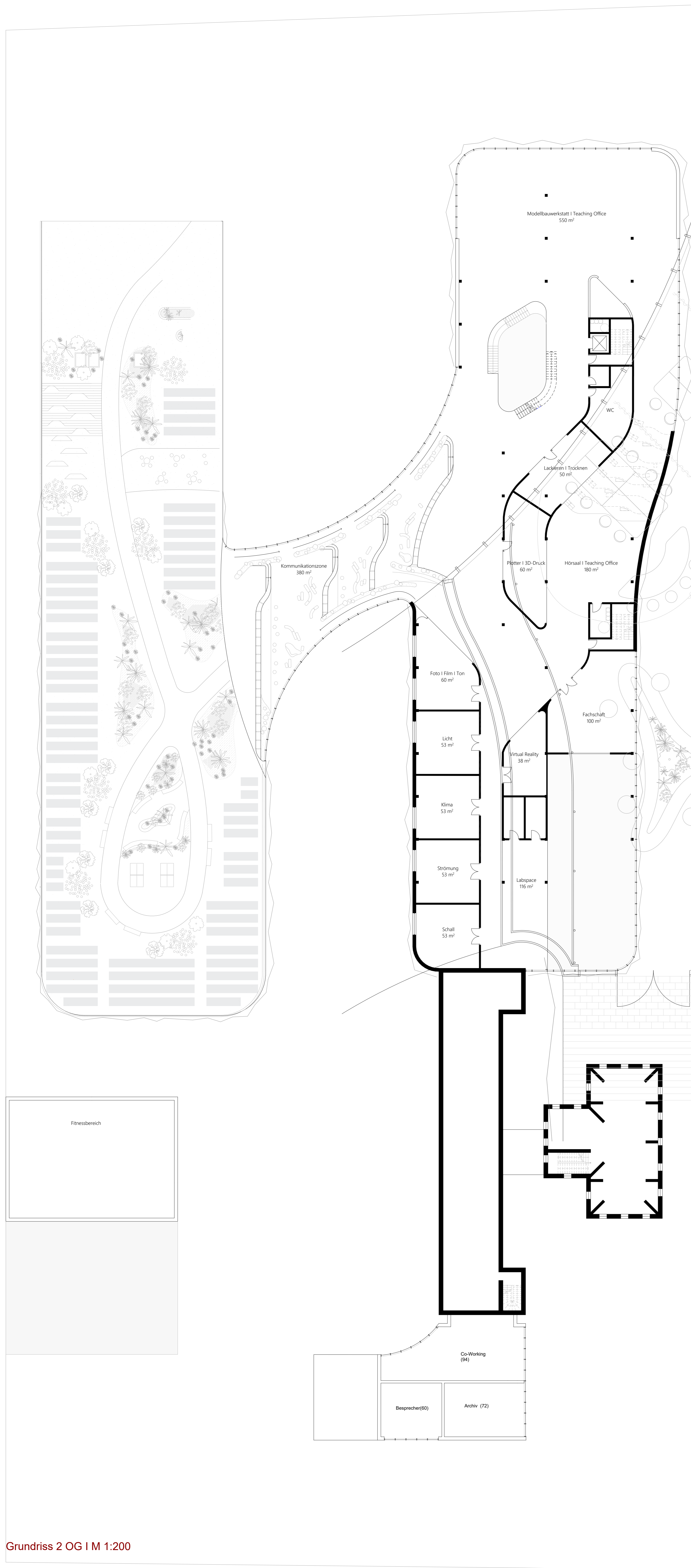

Vertiefungsbereich Teaching Offices | M 1:50 | Theresa Brinkmann

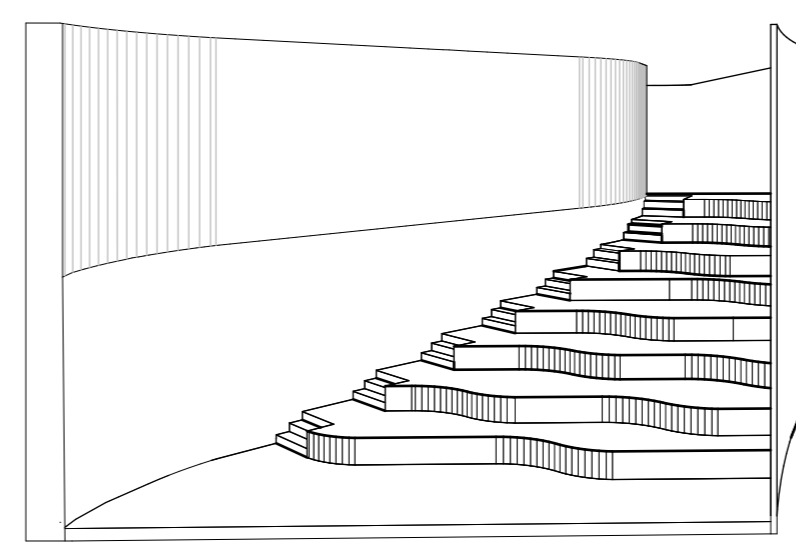

Perspektivisch Hörsaal

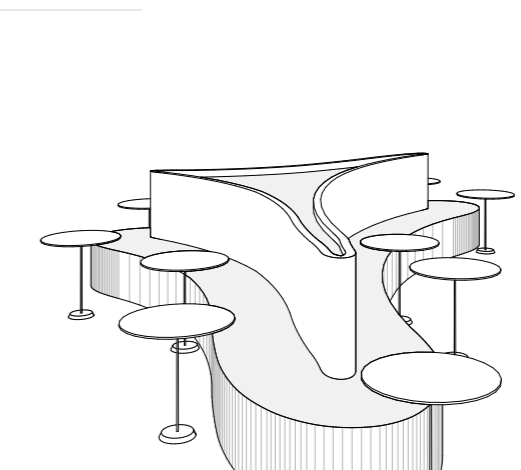

Möbellflow (Konzeptidee)

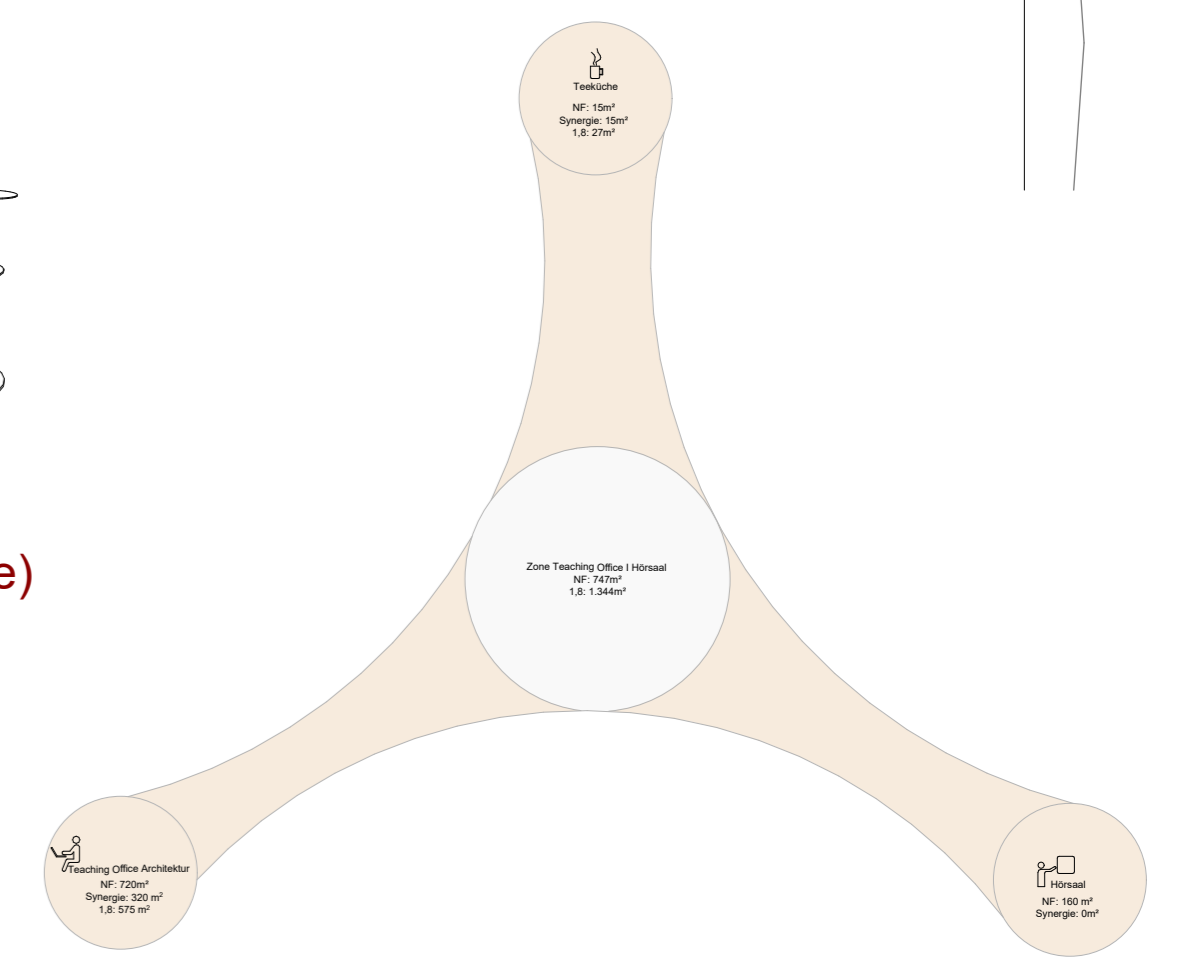

Synergiebereiche Teaching Offices

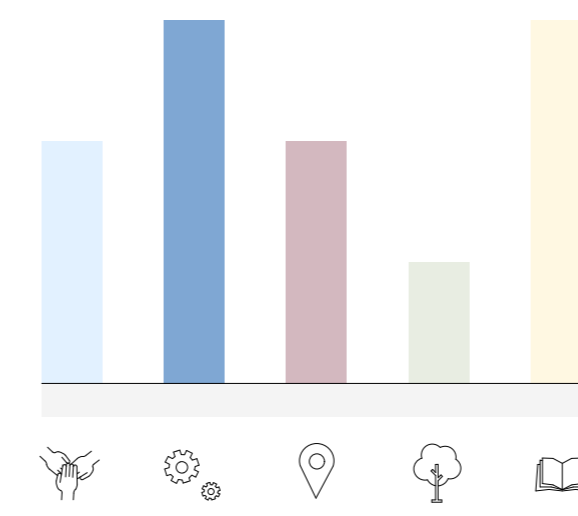

Teaching Offices

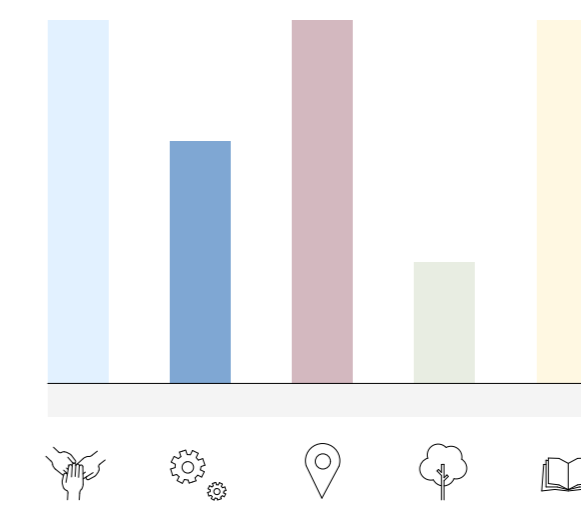

Hörsaal

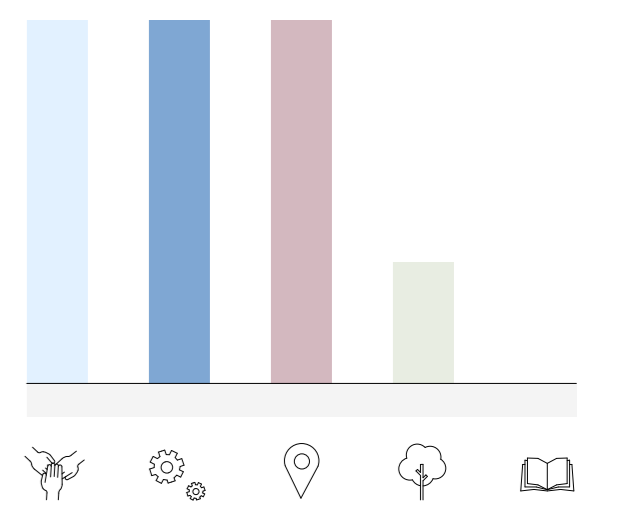

Küchen

Grundriss 2 OG | M 1:200

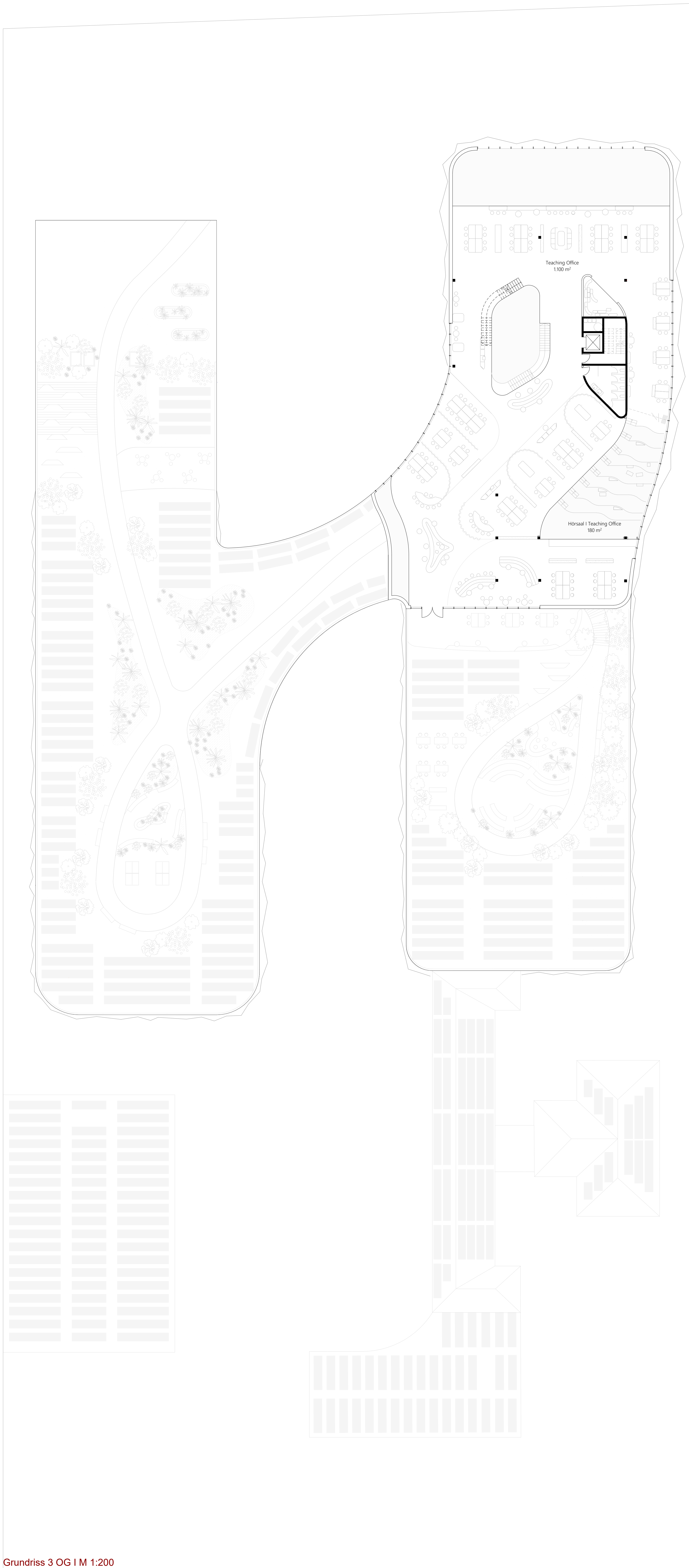

Grundriss 3 OG | M 1:200



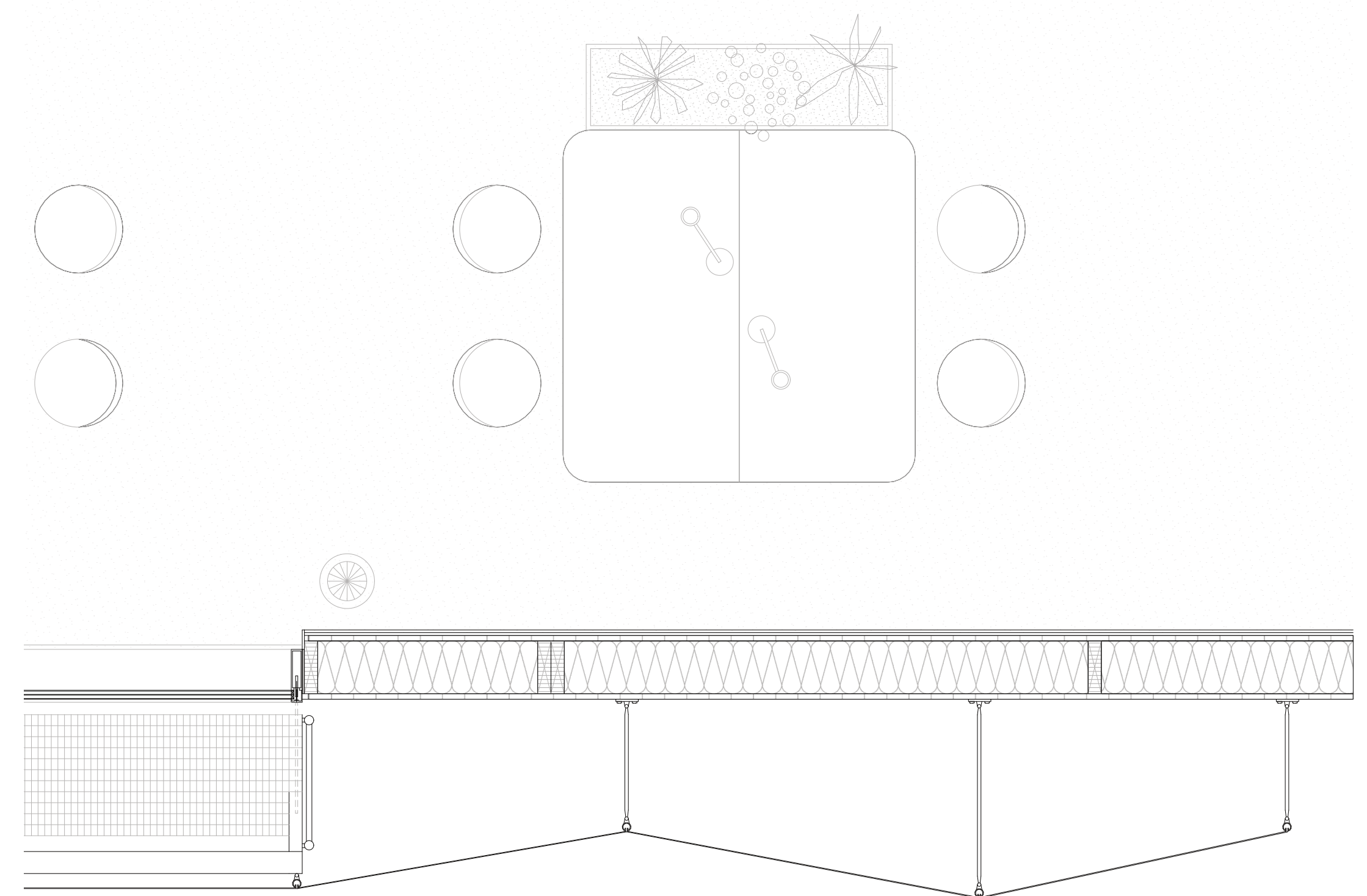
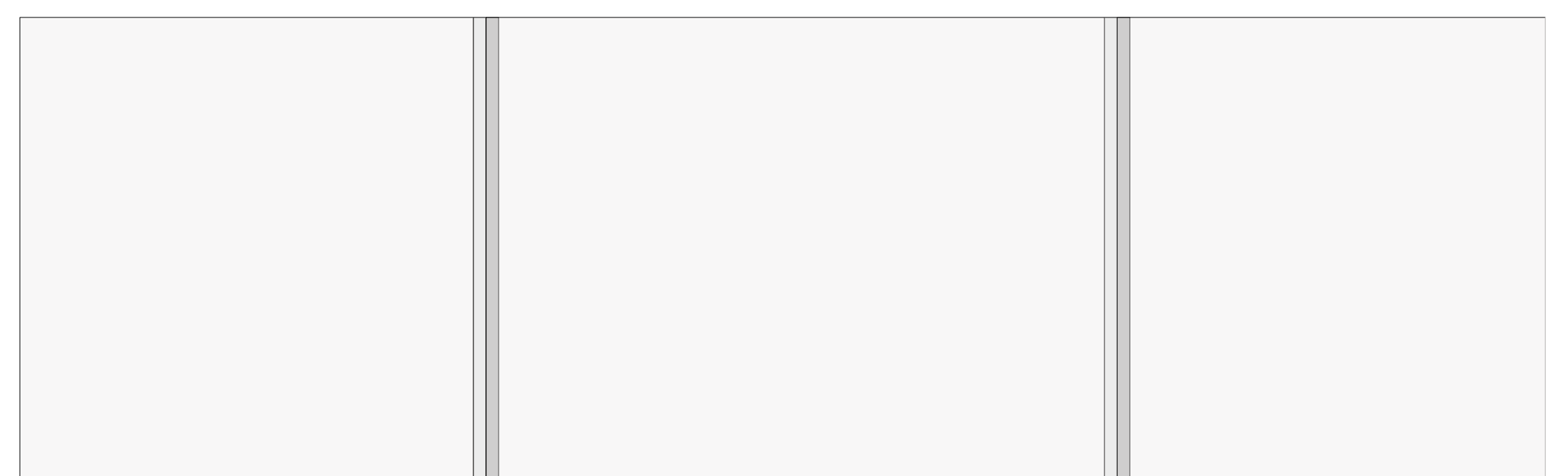
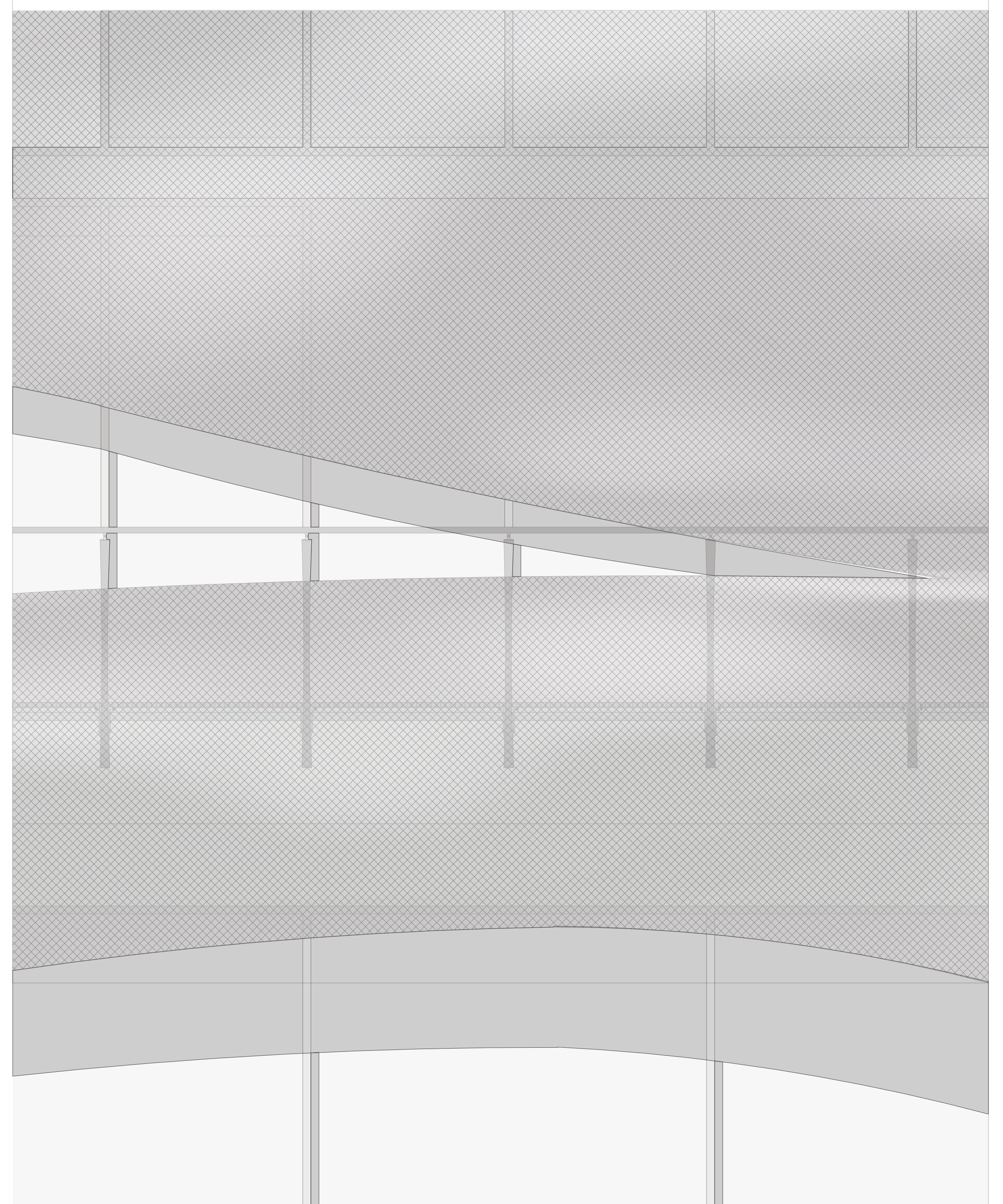
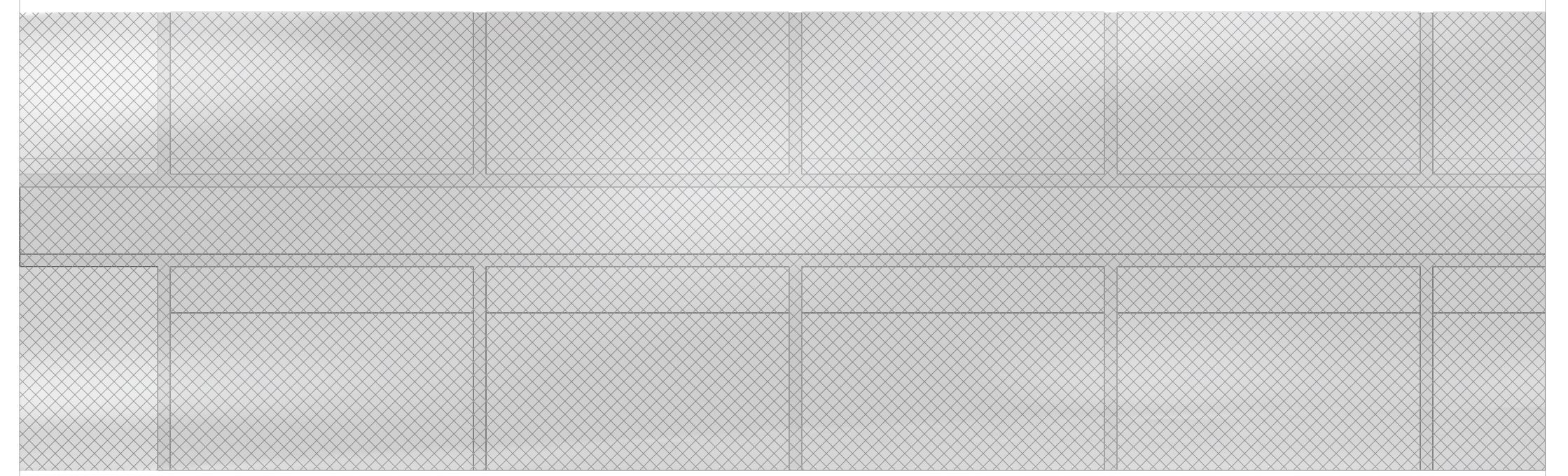
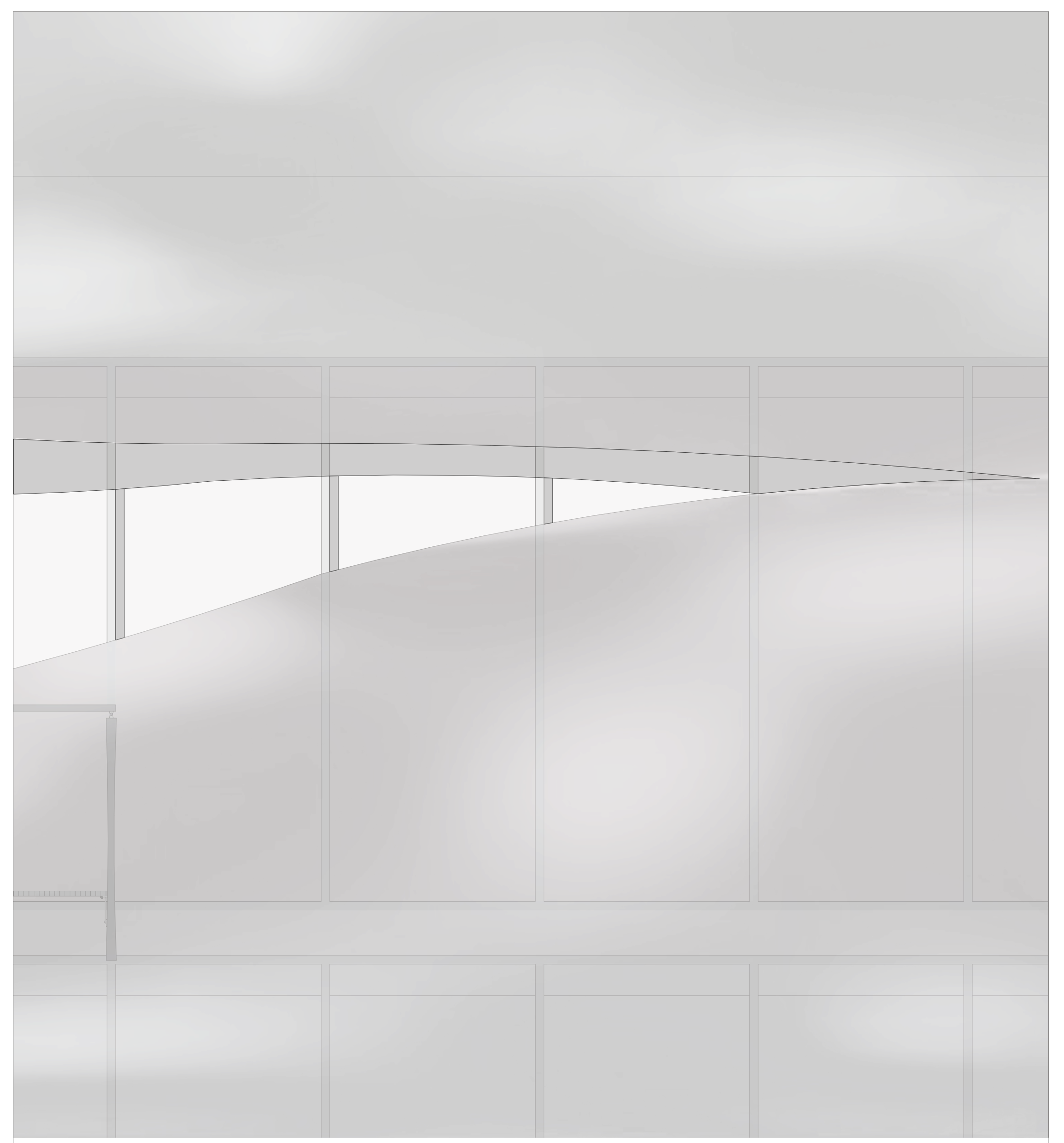
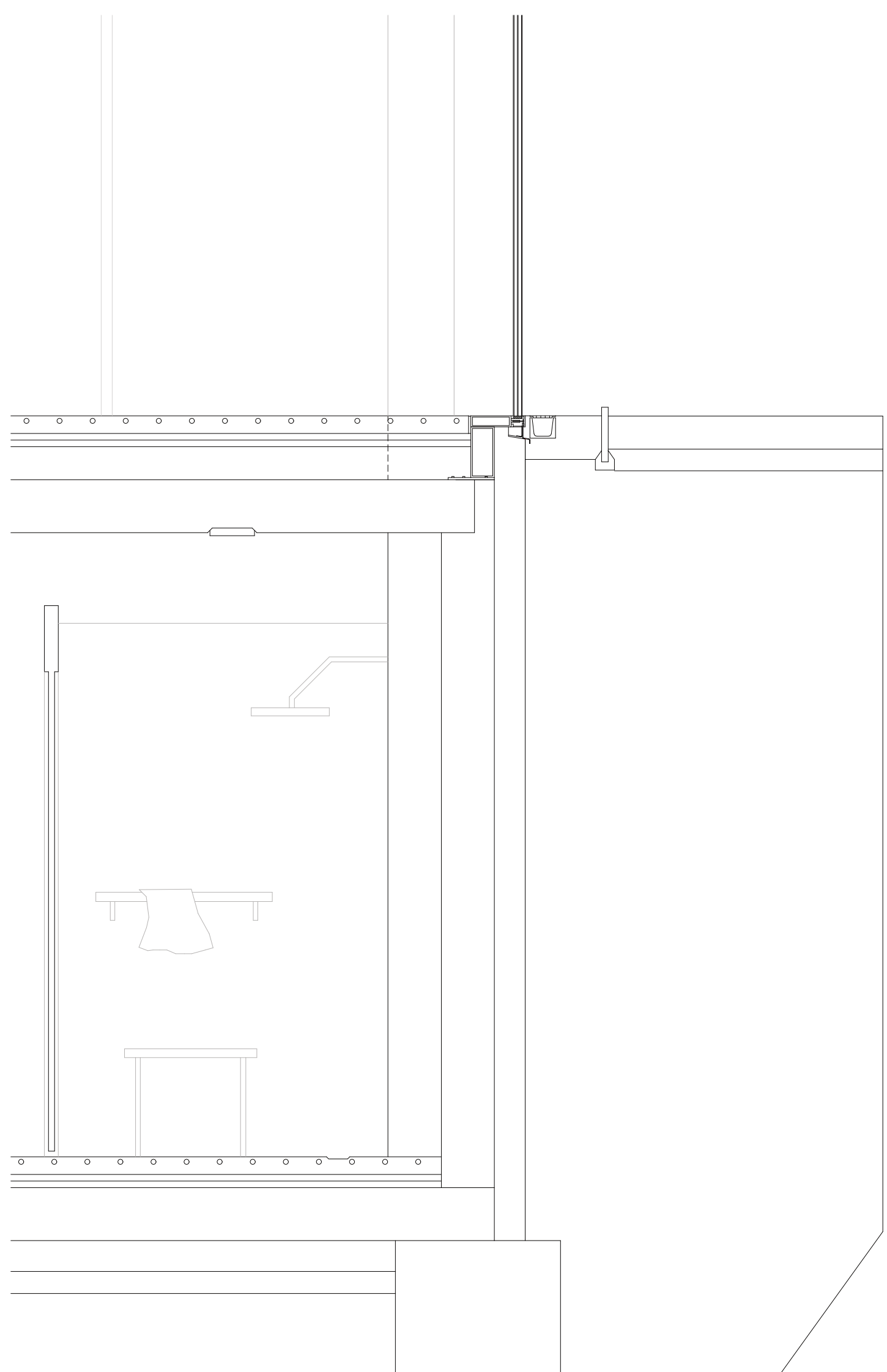
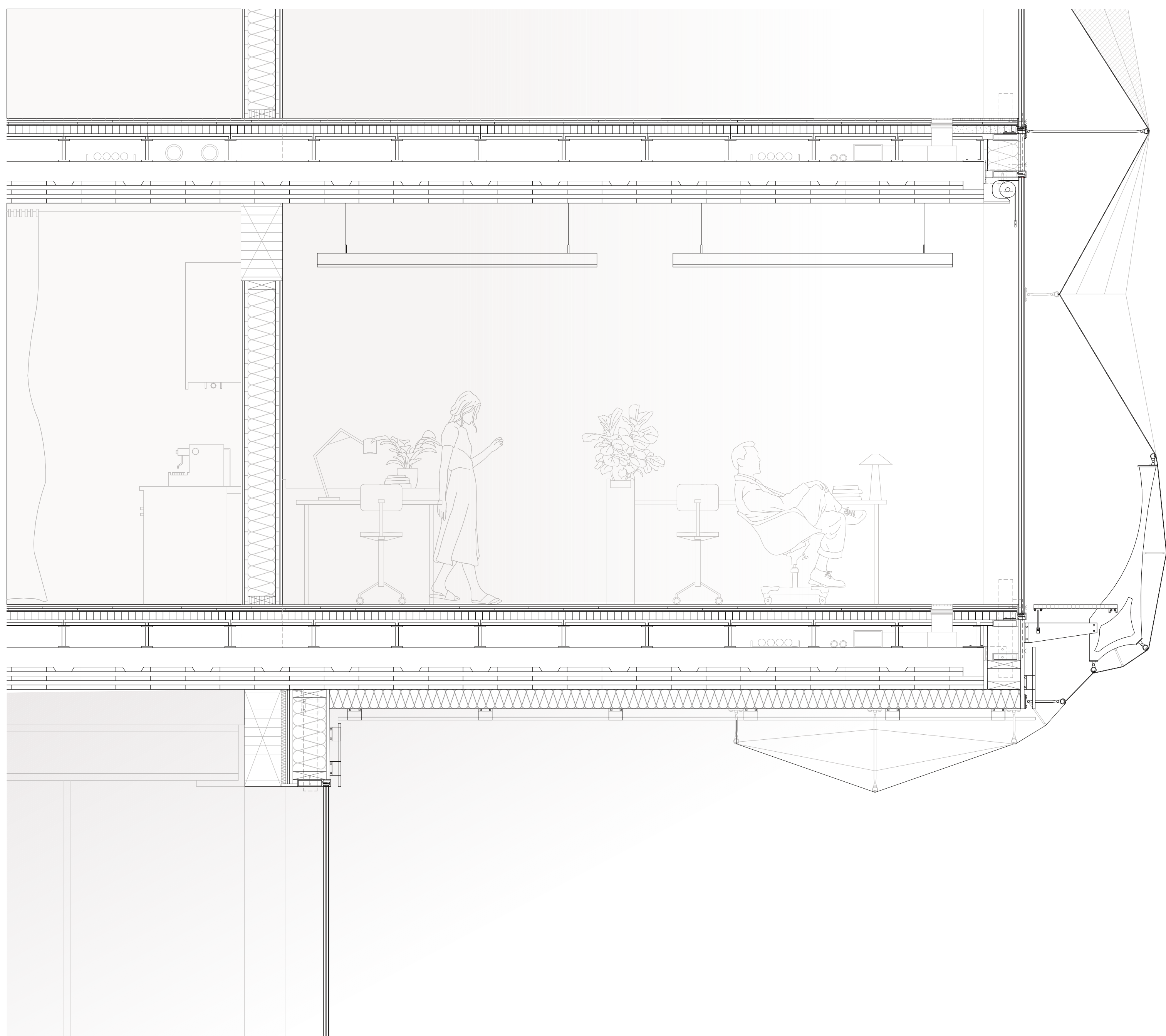
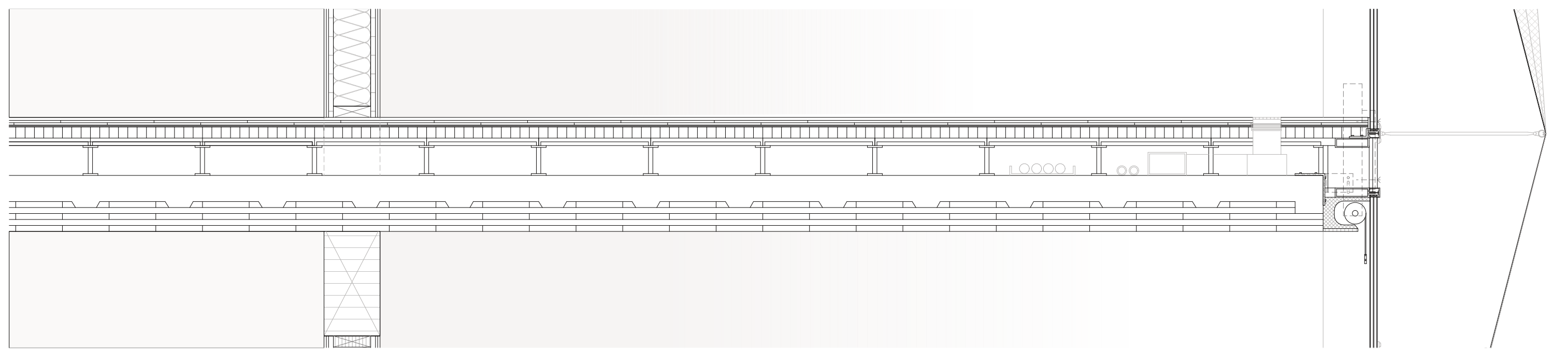
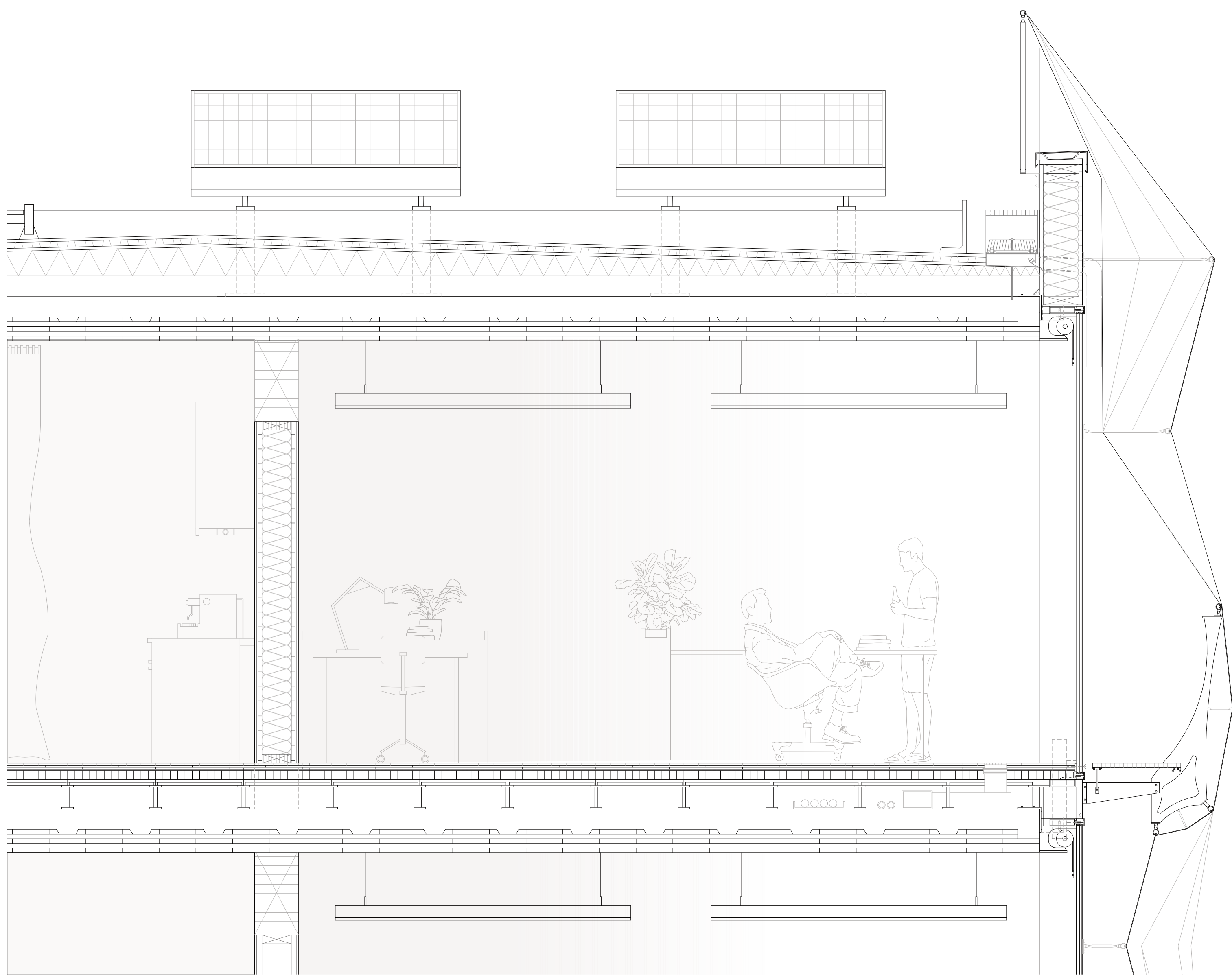

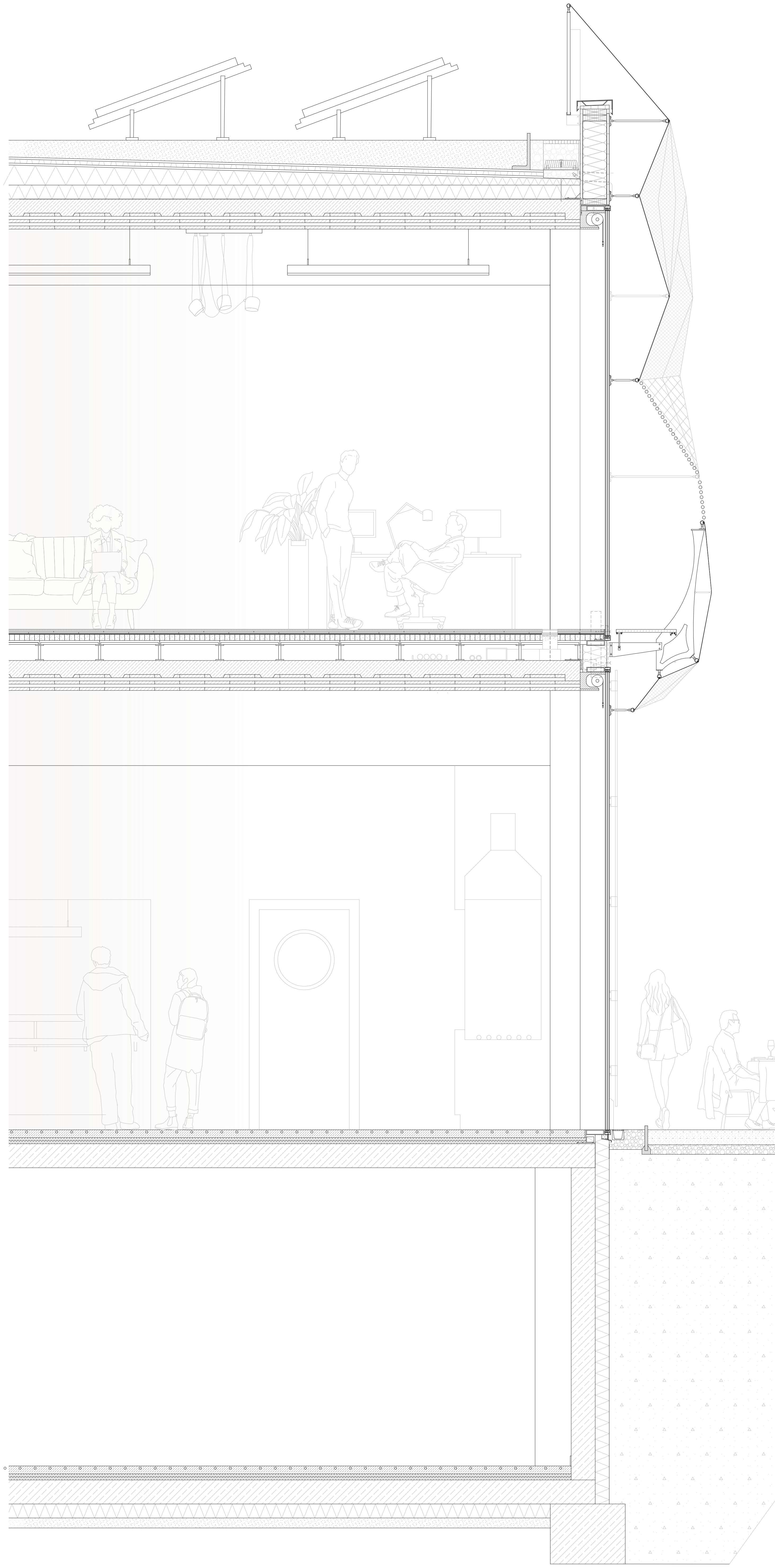

Fassadenschnitt Mensa | Arbeitsbereiche | M 1:20 | Marie Schütz | Luisa Unger

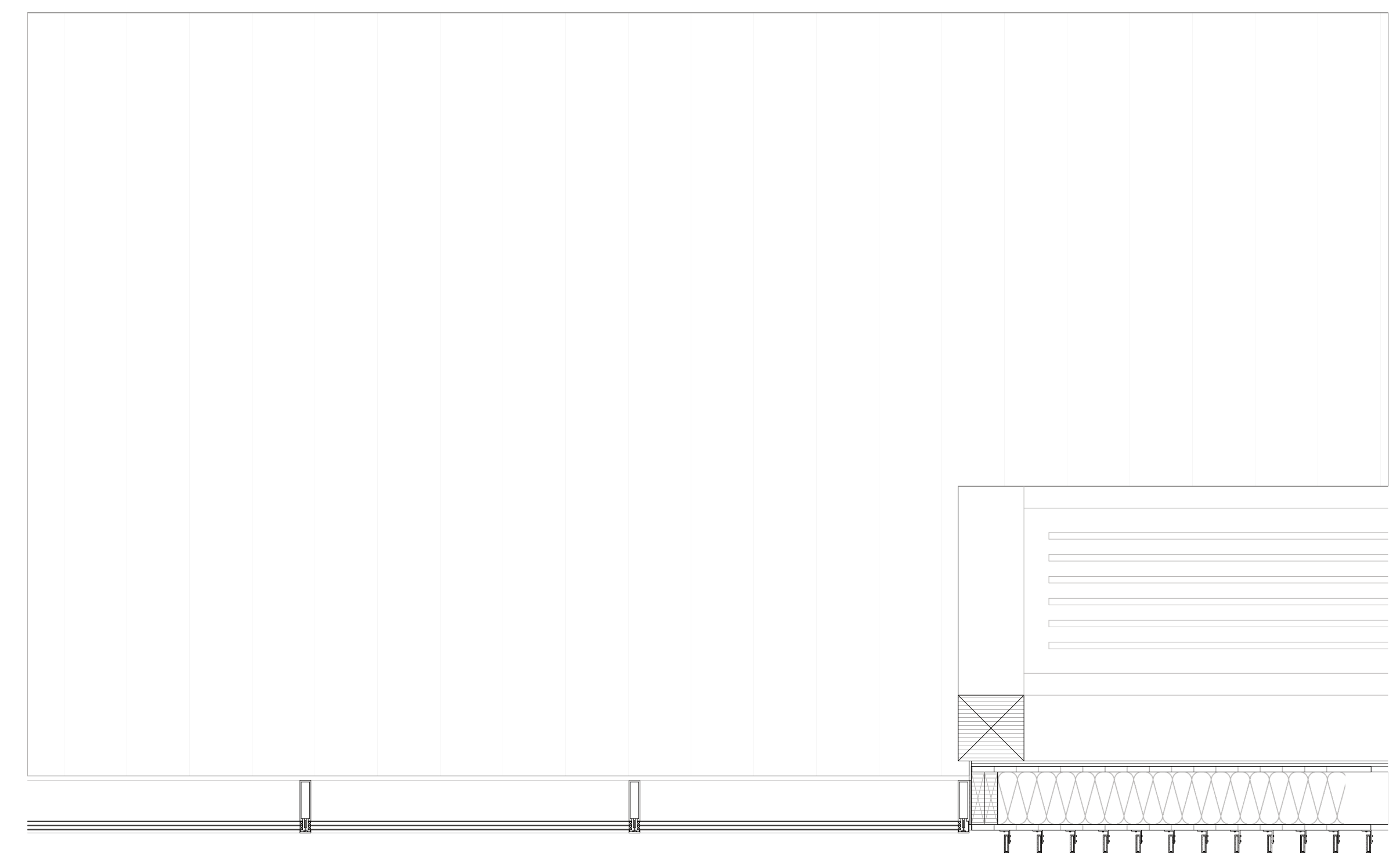
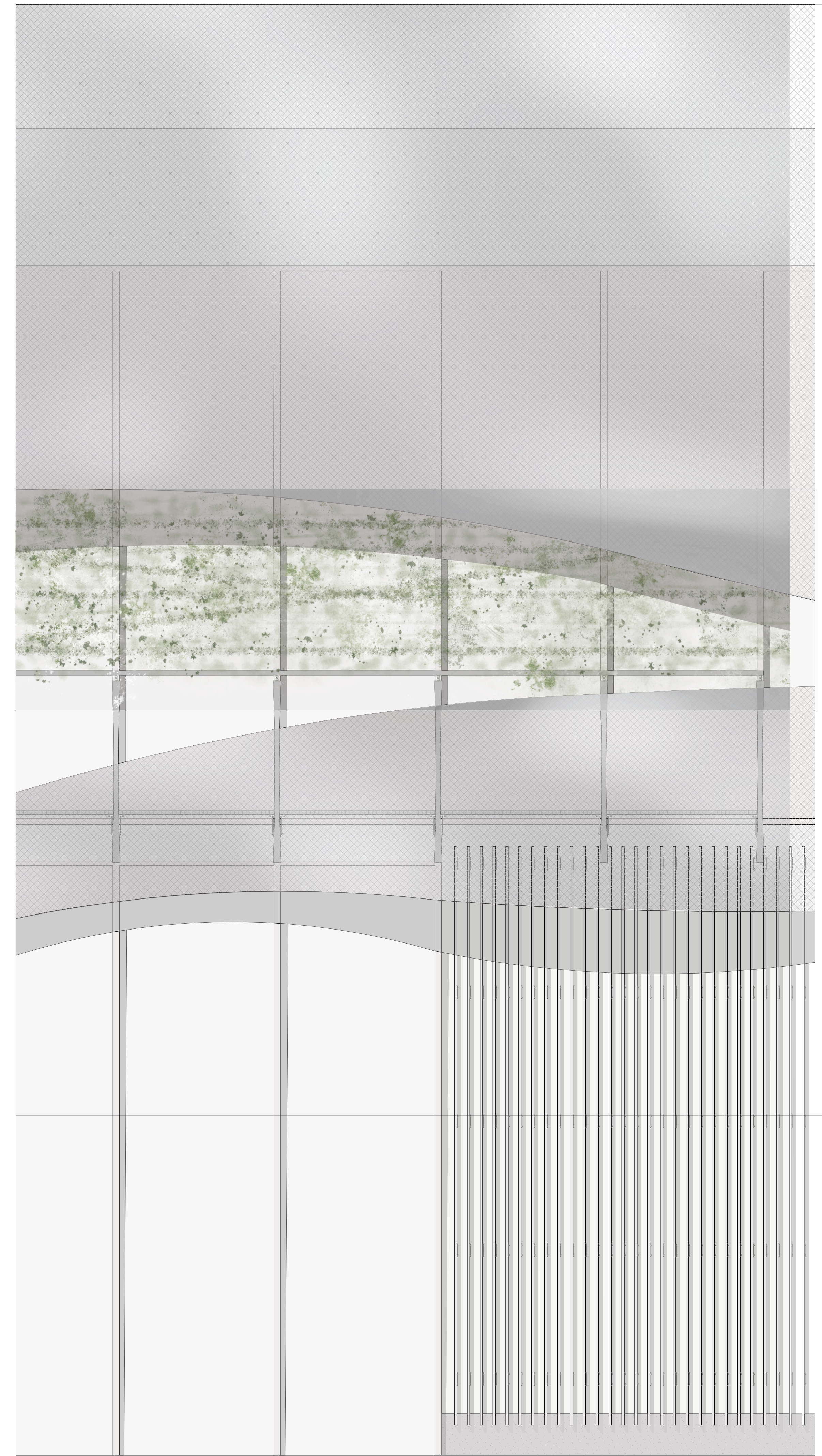

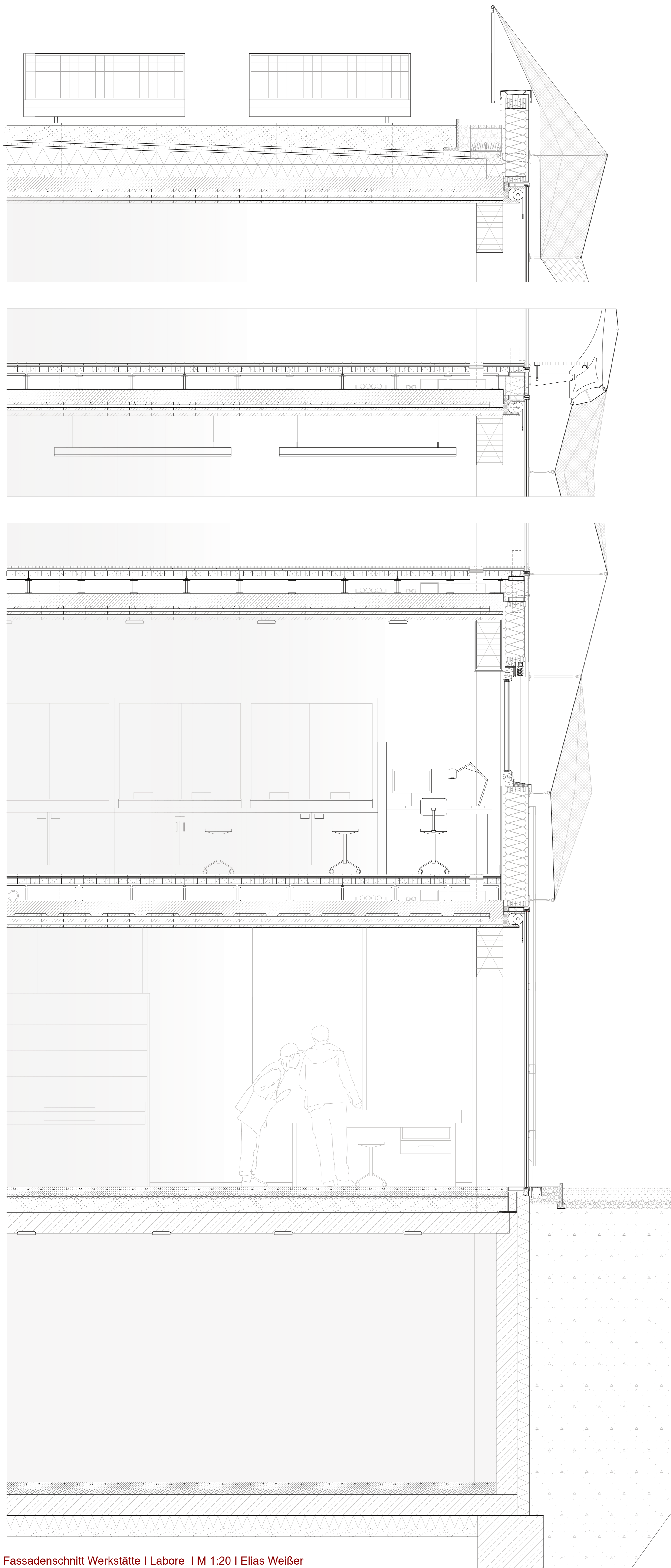

Fassadenschnitt Werkstätte | Labore | M 1:20 | Elias Weißer

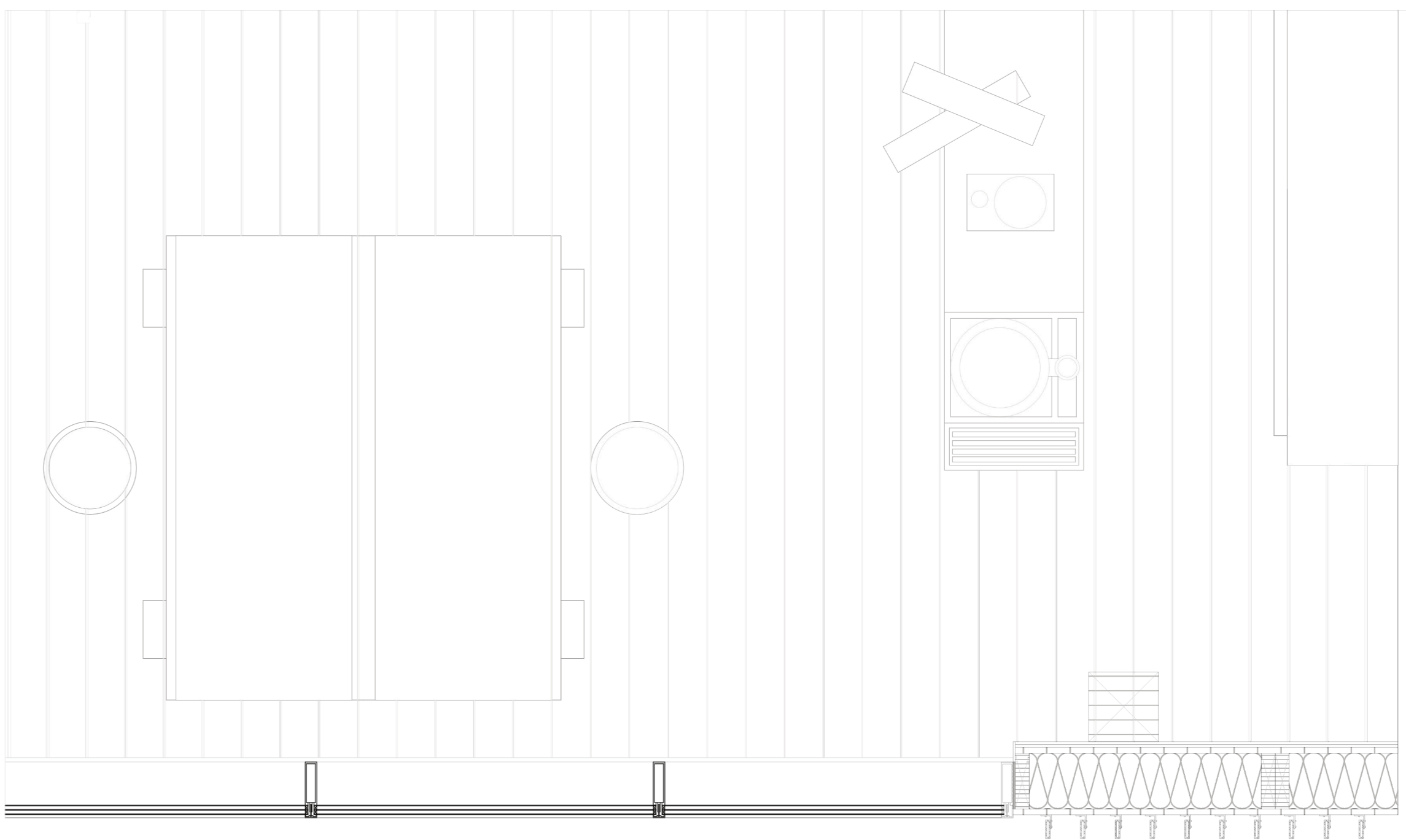
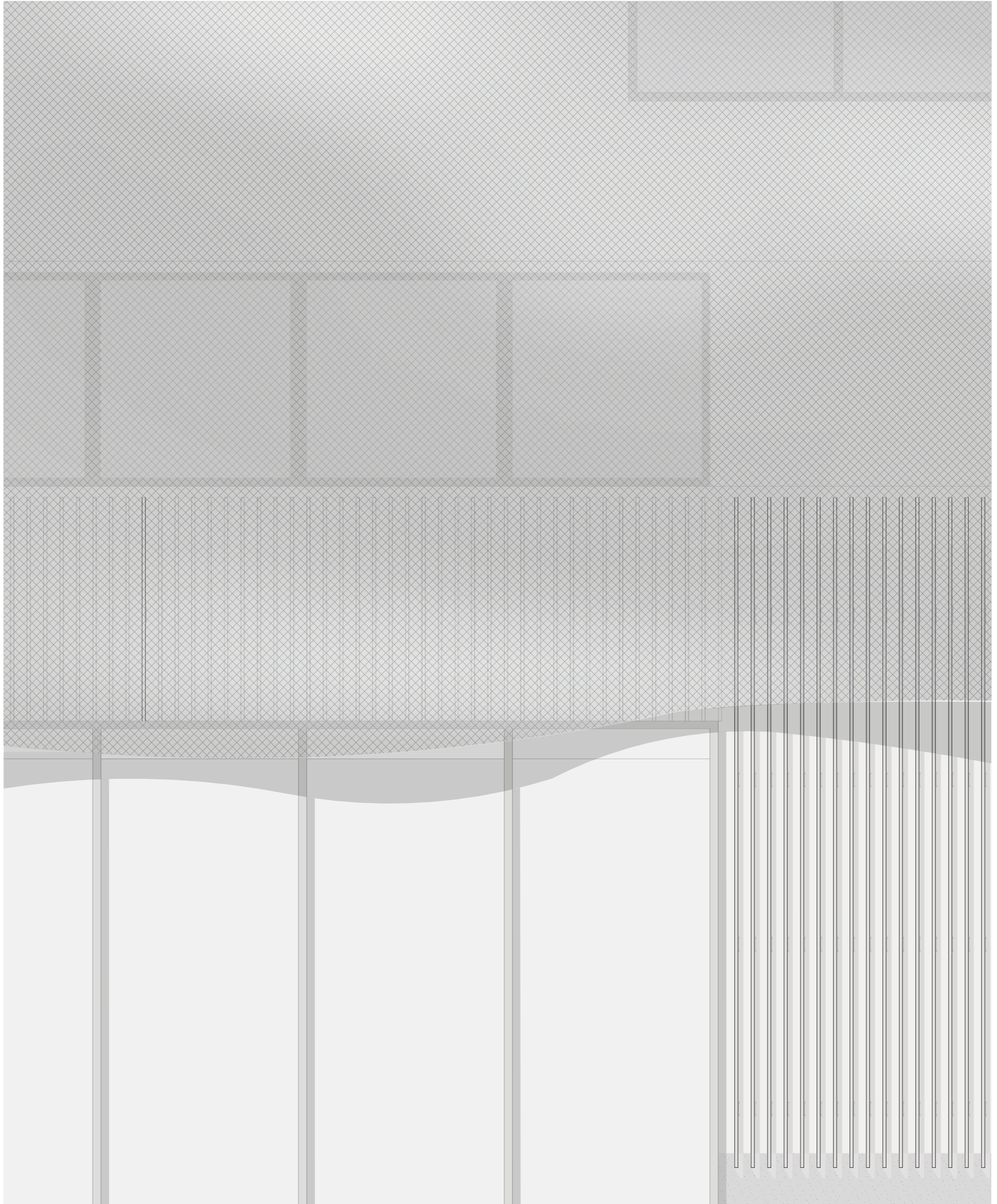
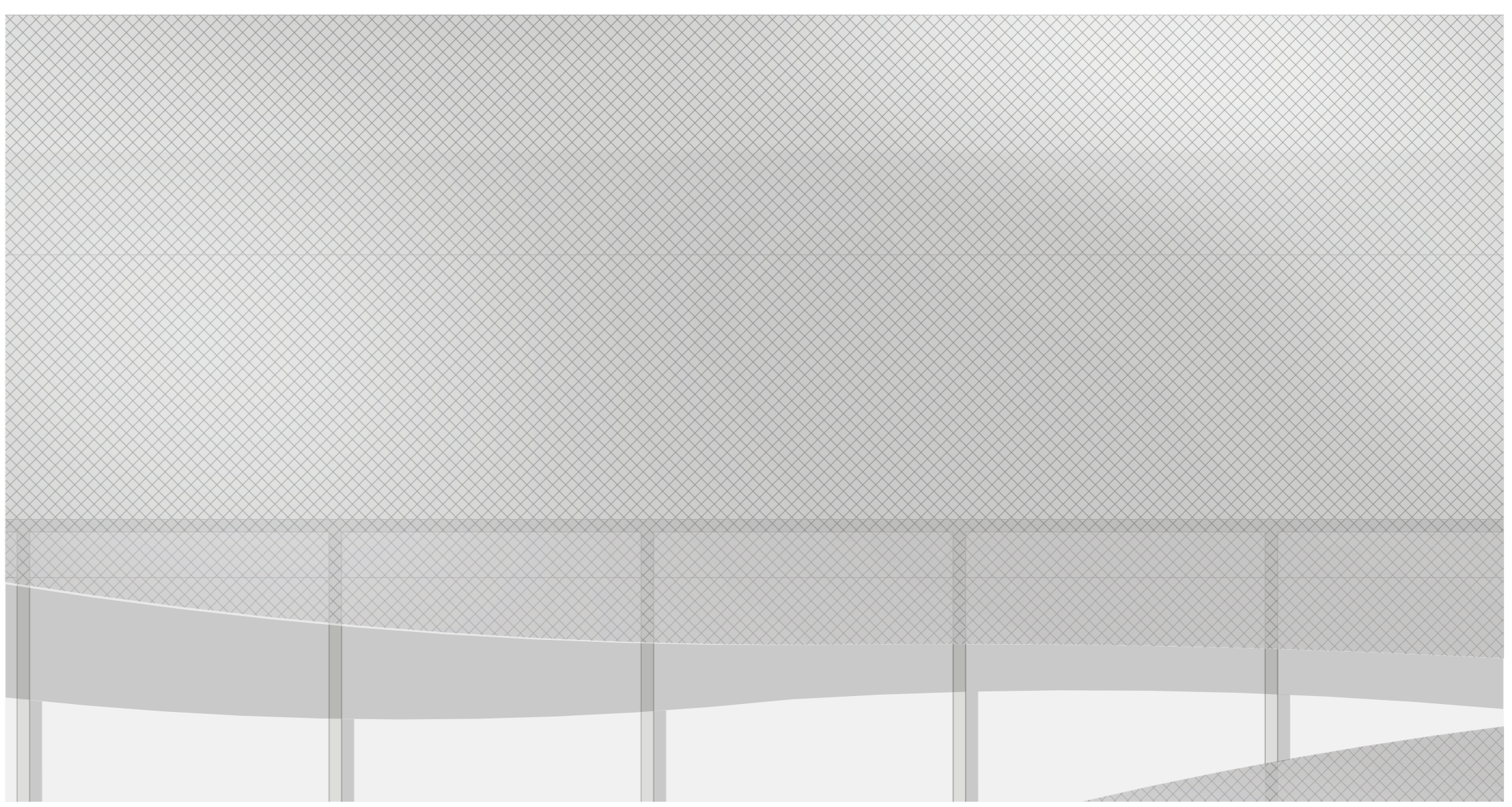

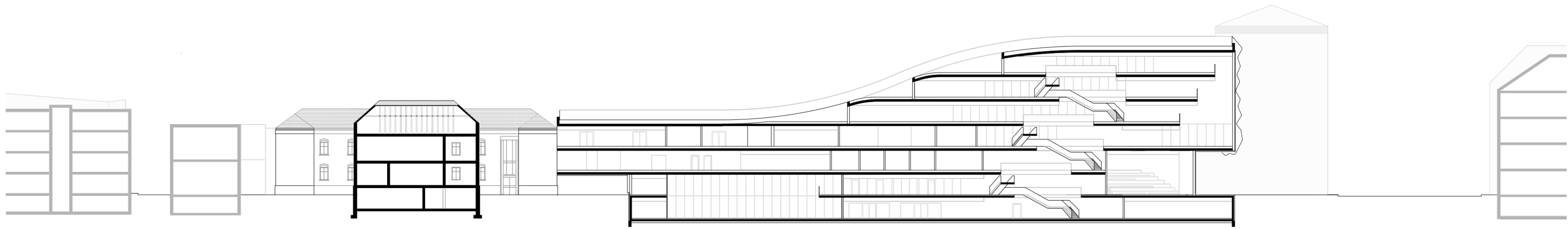

Schnitt A-A | M 1:200

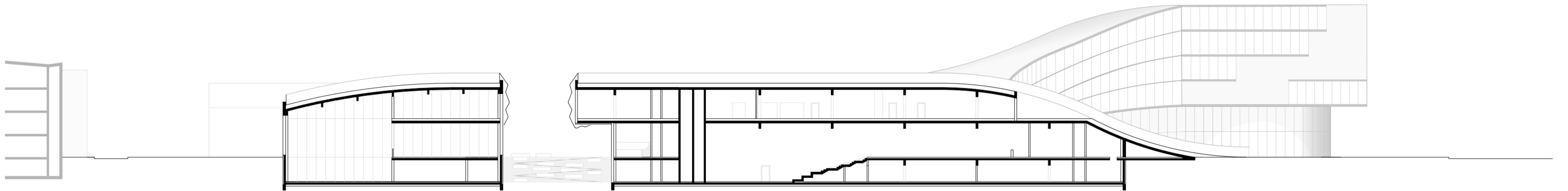

Schnitt B-B | M 1:200

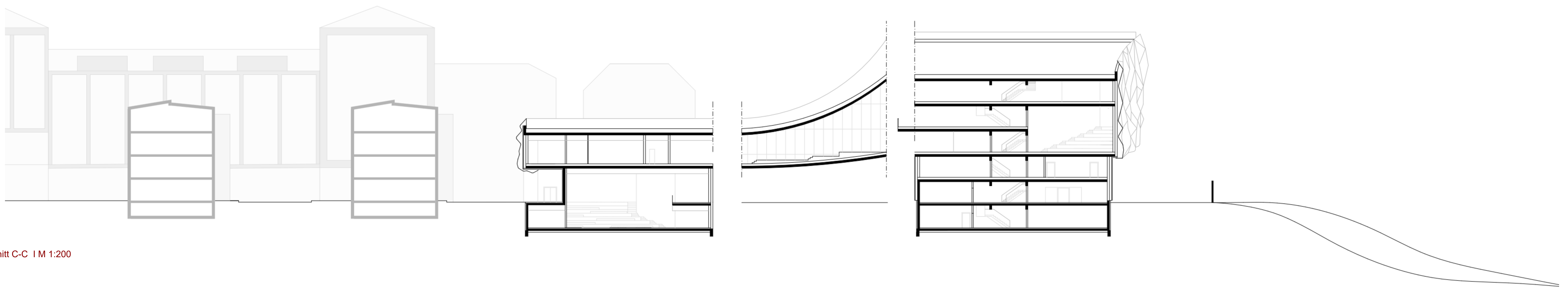

Schnitt C-C | M 1:200

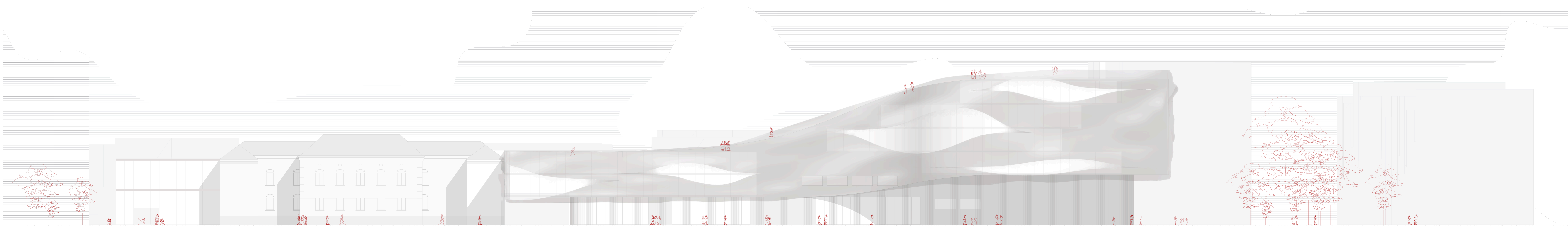

Ansicht Ost | 1:200

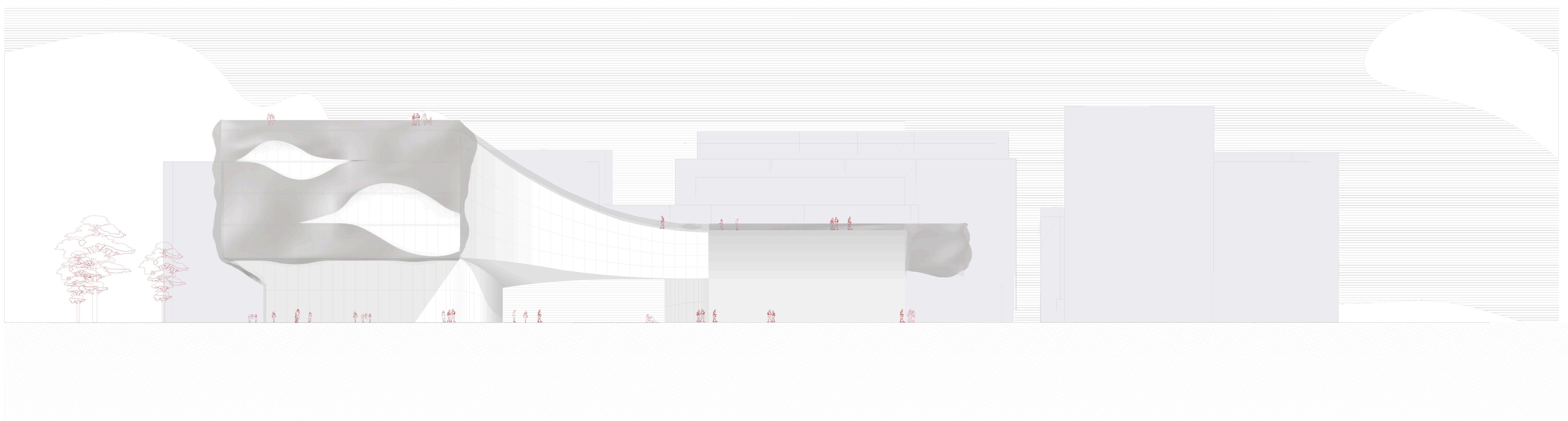

Ansicht Nord | 1:200

